



Optimizing Production: Advanced Display Metrology Solutions

MATT SCHOLZ | NOVEMBER 4, 2025



A Konica Minolta Company

Course Agenda



I. Measurement Principles



II. Measurement Equipment & Calibration



III. Measuring Specific Display Characteristics



IV. Addressing Emerging Display Types & Integrations

MATT SCHOLZ, SALES DIRECTOR

As a sales director with over 15 years of experience working in metrology applications, Matt has a fundamental understanding of the growing challenges in industries from automotive to consumer electronics, including increased performance and quality control for displays, lighting, and illuminated components. Matt has led projects at all levels of the supply chain, from integrators to suppliers to major OEMs worldwide. Matt strives to build customer success by sharing his expertise on measurement equipment and providing a consultative approach to system integration for inspection applications.



A Konica Minolta Company

I. Measurement Principles

THE SCIENCE OF LIGHT & COLOR, DISPLAYS, METROLOGY &
UNITS OF MEASUREMENT

The Science of Light & Color

What Is Light?

Electromagnetic Spectrum

Light is made of **photons**: an electric field combined with a magnetic field, moving through space. Our eyes only respond to a limited range of wavelengths.

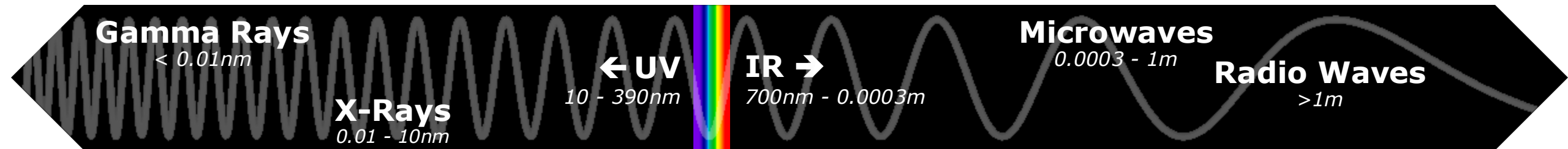

Radiometry

The science of the measurement of electromagnetic radiation at any wavelength. Radiometric optical instruments can measure infrared, visible, and ultraviolet light.

What Is Light?

Electromagnetic Spectrum

Light is made of **photons**: an electric field combined with a magnetic field, moving through space. Our eyes only respond to a limited range of wavelengths.

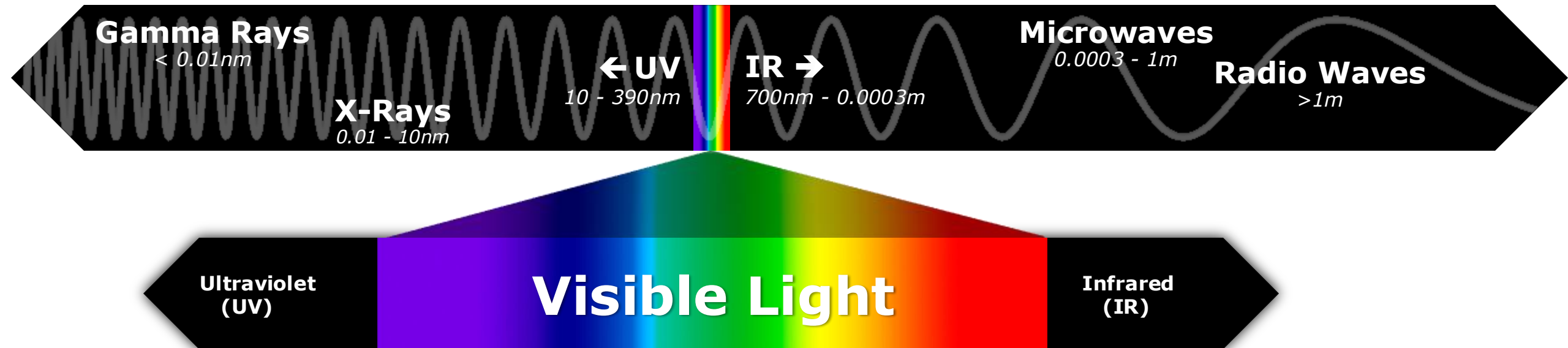

Spectral Power Distributions (SPD)

Every light source has an SPD, which describes a source's power (Watts) at each wavelength.

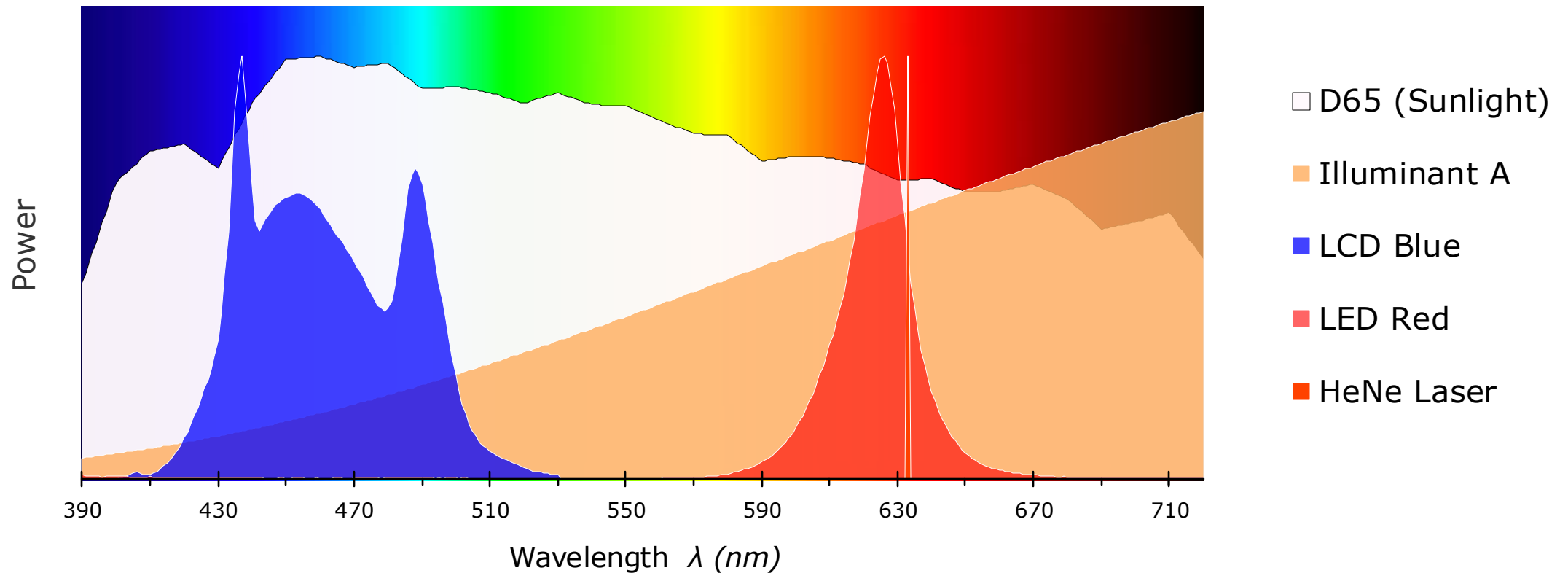

Human Vision

The human eye has three types of cones (S, M, and L) that are each sensitive to a range of wavelengths.

Understanding our visual response (**spectral sensitivity**) enables quantifying light as we perceive it.

The combined response of our 3 cones gives us a perception of color based on a given stimulus.

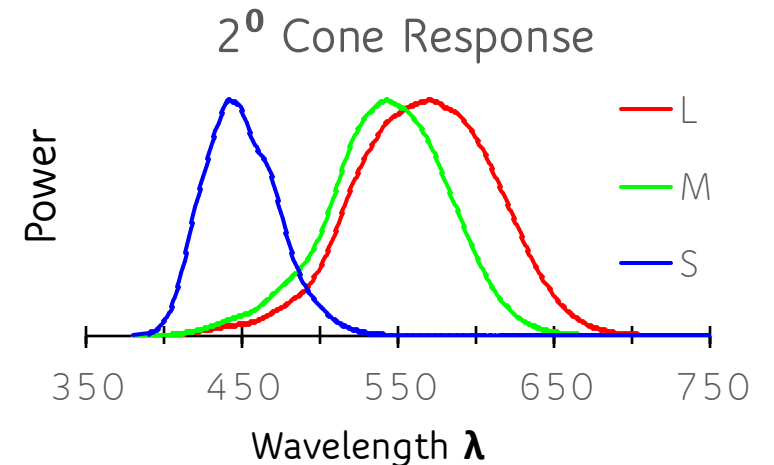
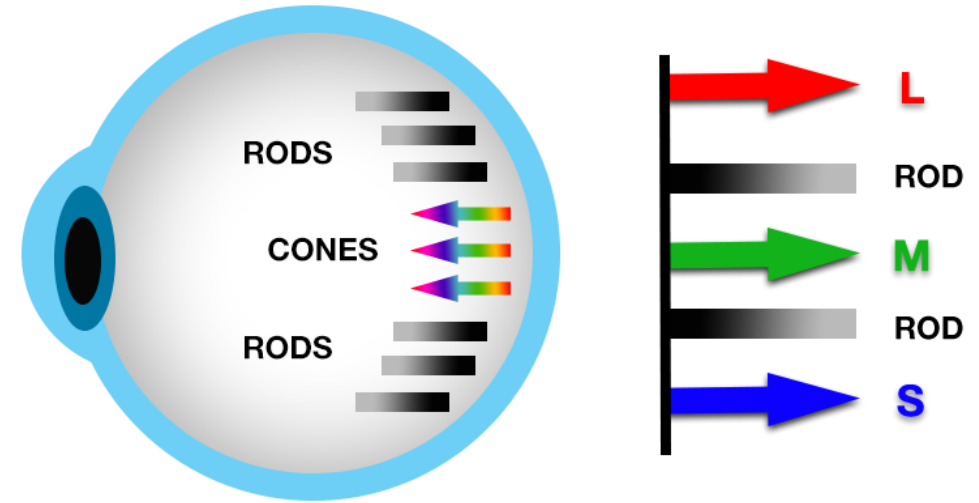

Photometry & Colorimetry



Photometry is the science of the measurement of **light** as perceived by the human eye.

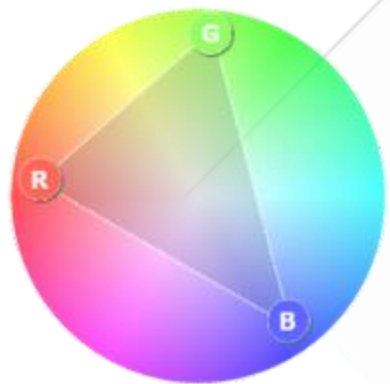

Colorimetry is the science of the measurement of **color** as perceived by the human eye

CIE Chromaticity Diagram

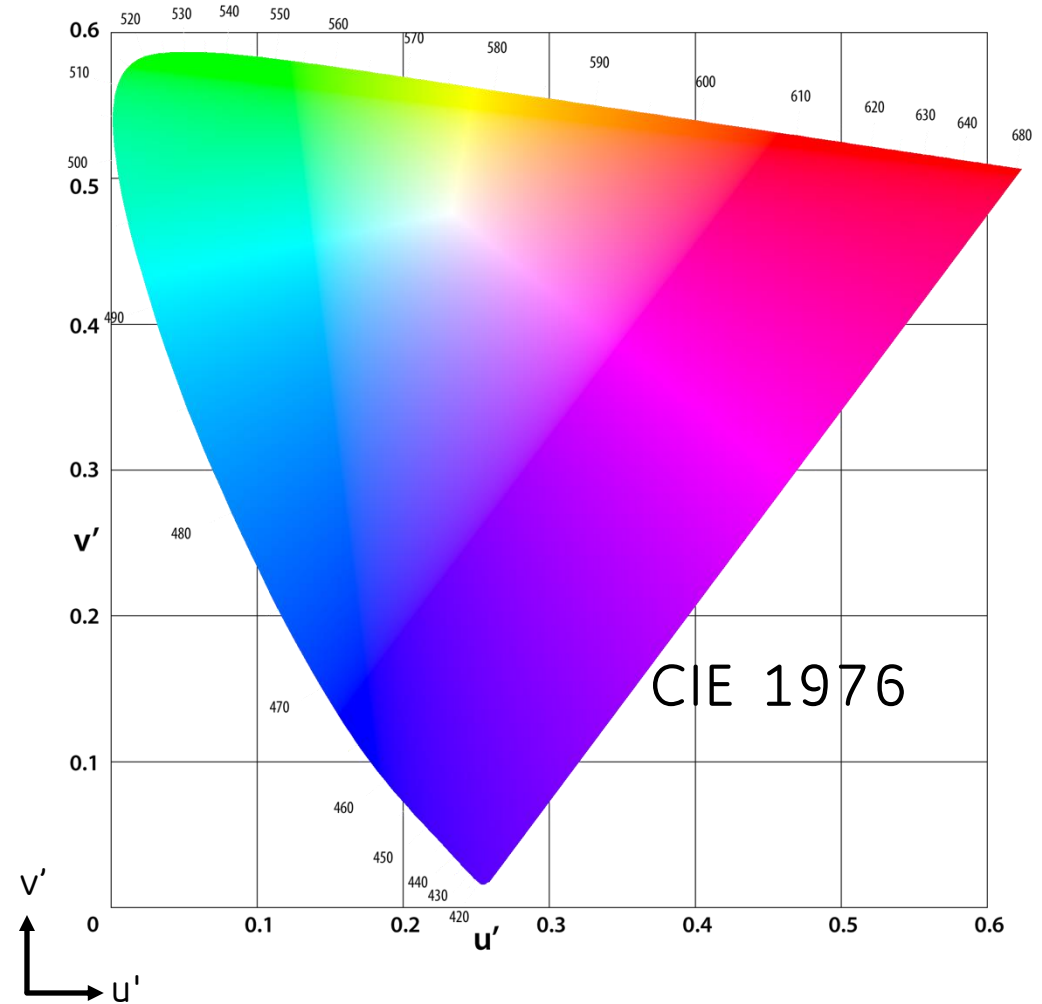
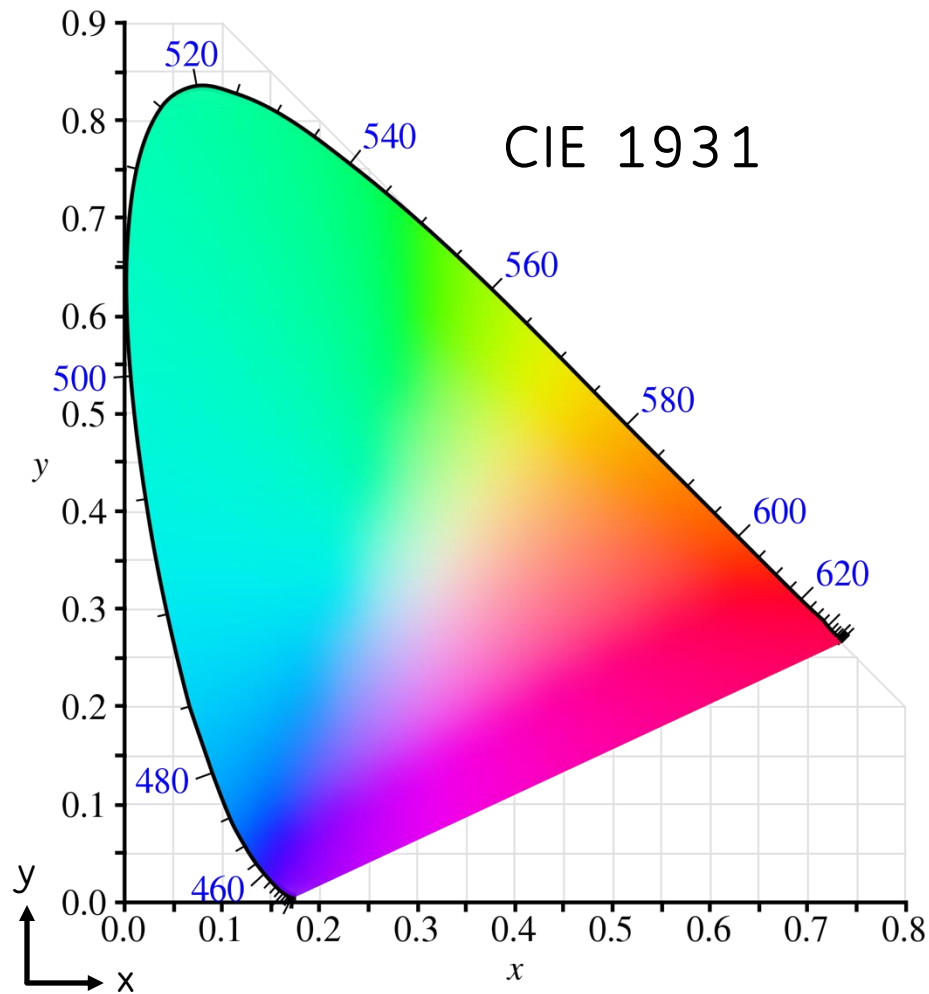

CIE Chromaticity Diagram

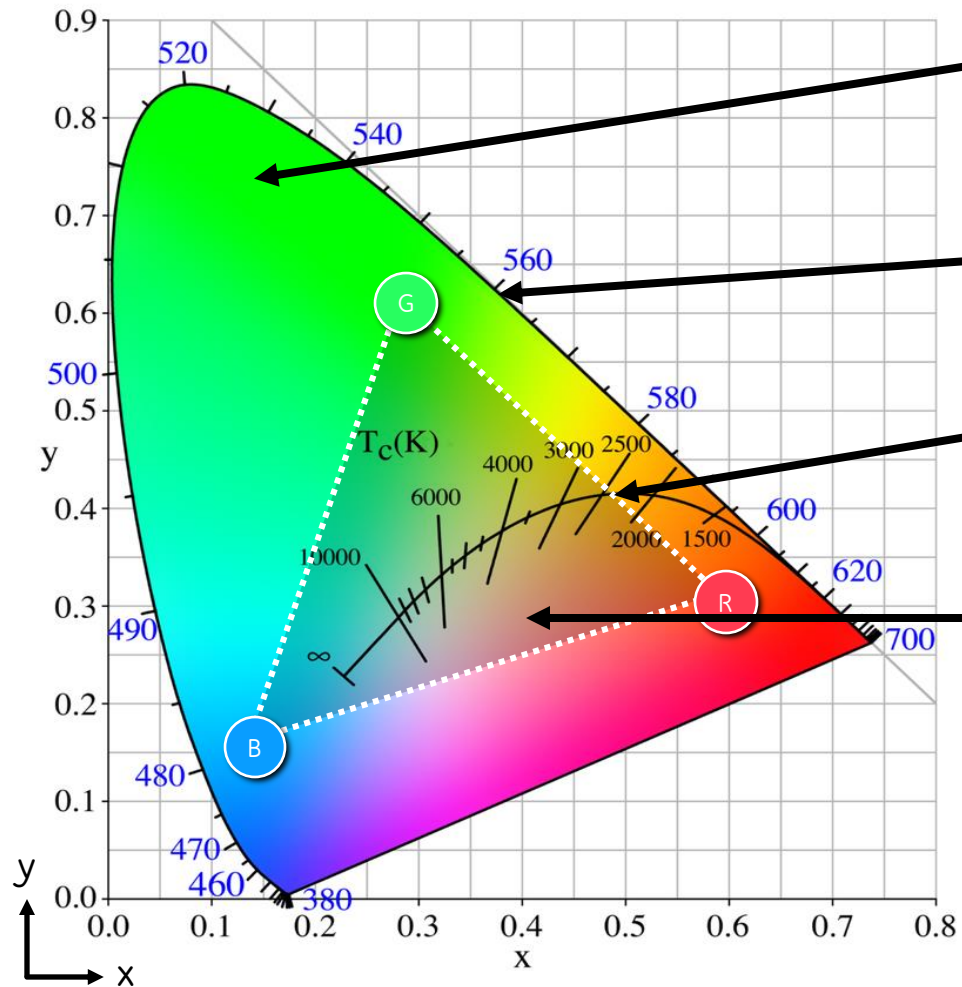

Color Space

*Every visible color to the human eye.
Colors given in coordinates (x,y)*

Spectral Locus

Wavelengths

Planckian Locus (Blackbody curve)

Defines color temperature of a source (Correlated Color Temperature, CCT, given in Kelvin)

Color Gamut

Range of colors that can be rendered by a device using the device's primaries.

R + **G** + **B**

MacAdam Ellipses

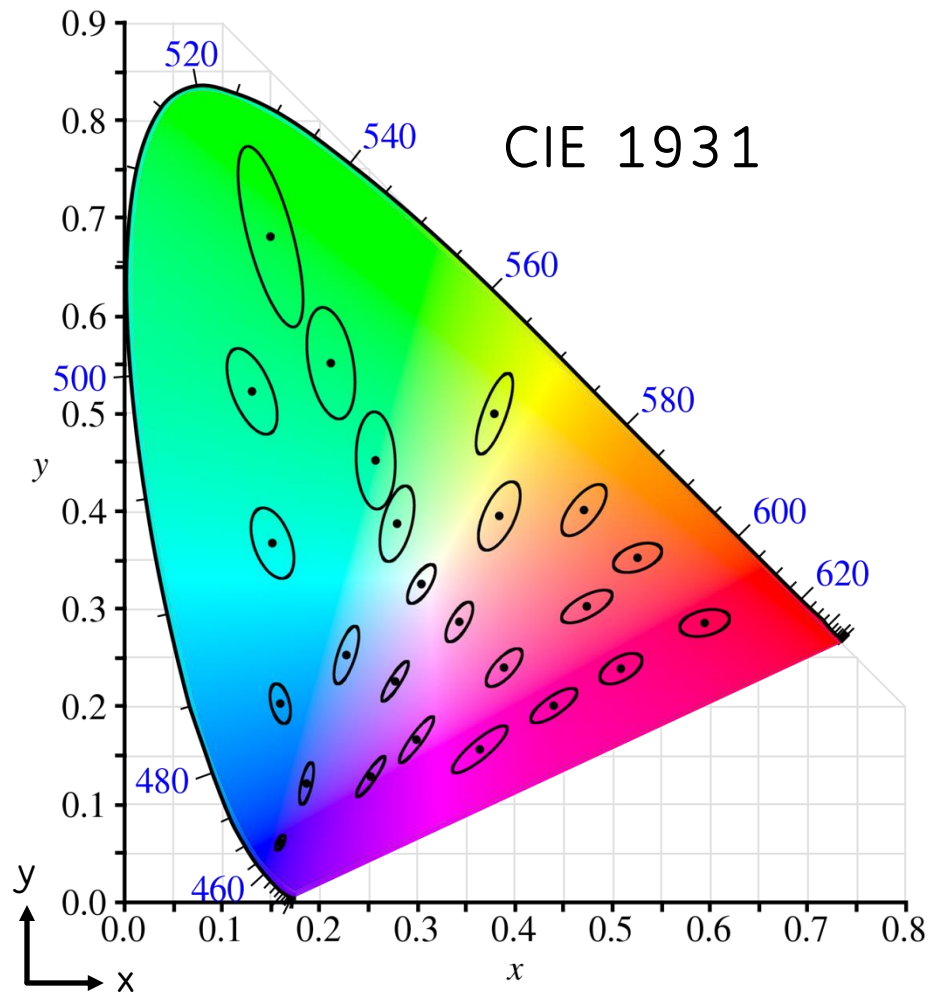

A region on a chromaticity diagram which contains all colors which are indistinguishable, to the average human eye, from the color at the center of the ellipse.

**Ellipses shown left are 10X actual size*

II. Measurement Equipment & Calibration

METERS, SPECIFICATIONS, AND MEASUREMENT ACCURACY

Spectroradiometers

Principle of Spectroradiometers

Refraction at prism

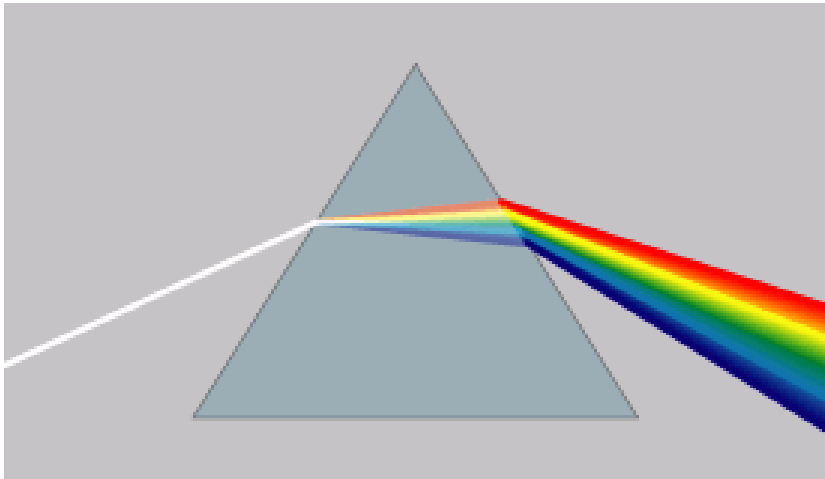

Separation of the spectrum dependent on refractive index $n(\lambda)$

- Spectral resolution depends on wavelength
- Higher dependence on Temperature

High throughput

Diffraction at grating

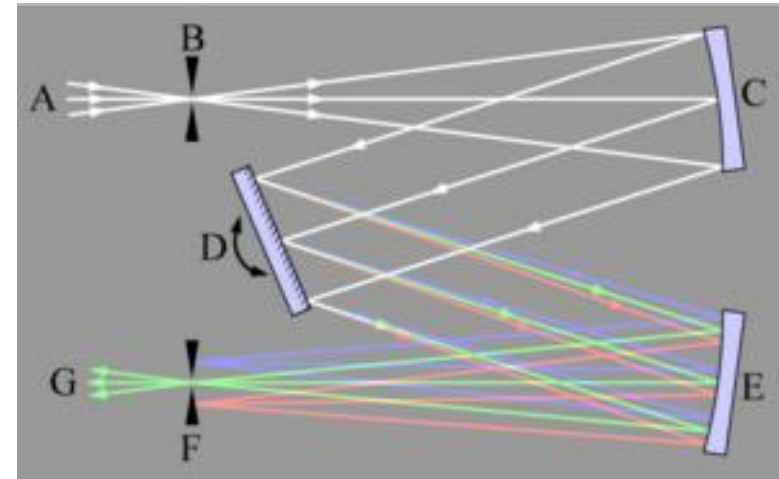

Separation of spectrum dependent on geometry

- Constant resolution across wavelength range
- Linear dependence on grating angle D

Wide spectral range

Array Spectroradiometers

- CCD/CMOS array captures entire spectrum simultaneously
 - No moving parts
 - Measurement time down to a couple of milliseconds
- Superior in speed and robustness

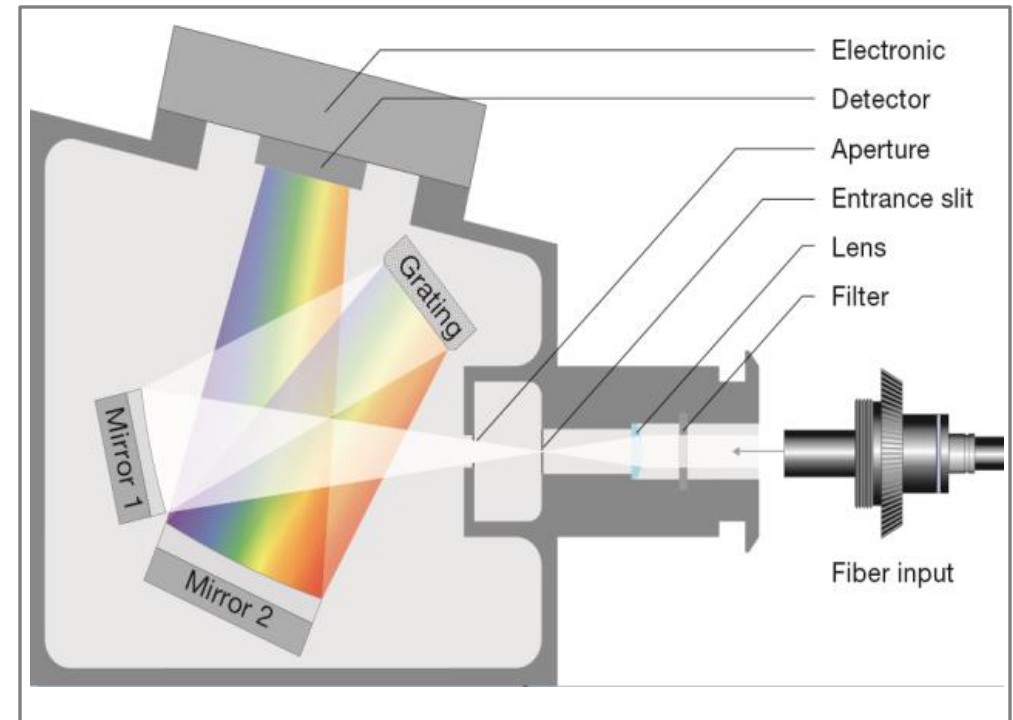

Crossed-Czerny-Turner geometry

Key Performance of Spectroradiometer



*Example display test system
with telescopic optical probe and spectroradiometer*

- Suitability of optical probe
 - Differentiation to a spectrometer
- Stray light performance
- Bandpass
- Linearity
- Stability and Repeatability
- Calibration errors
 - Wavelength scale
 - Traceability
 - Low measurement uncertainty
 - Regular recalibration & audit

Optical Probes for Spot Measurements

- Spot measurements use incoupling optics with imaging optics
- Measurement orientation
 - Spot measurements generally measured in perpendicular direction
 - Setup in a photogoniometer allows angular measurements
- Probes should be equipped with a view finder camera
- Suitable optical probe depends on the application, e.g. mimics the human eye pupil in AR/VR applications

Examples of incoupling optics suitable for display metrology

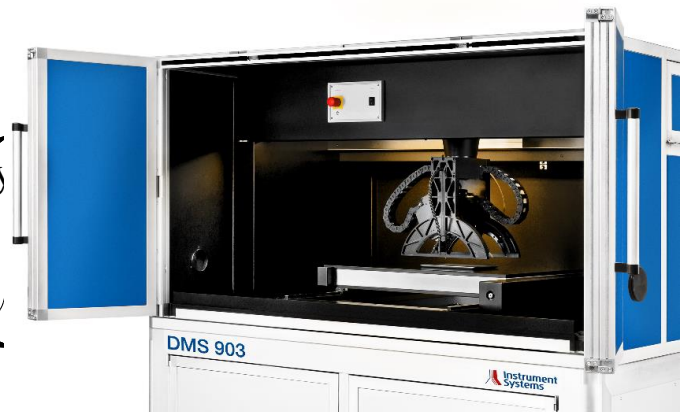
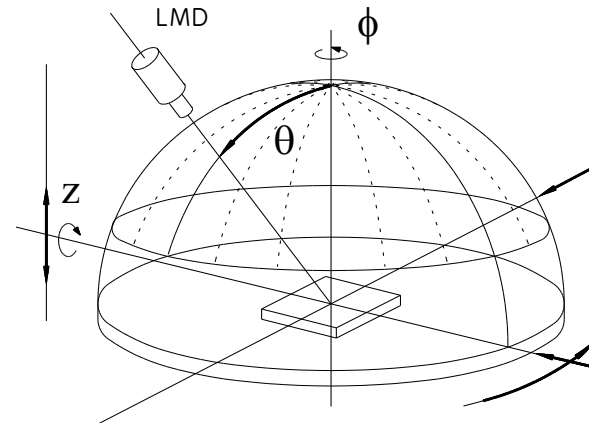

Array Sensor Technologies

- Back-illuminated CCD array:
 - high sensitivity for fast testing
 - high sensitivity in blue and UV
 - highest dynamic range
 - highest performance, but highest price
- CMOS array:
 - Fastest
 - High pixel number feasible
 - highest speed, high resolution
- Front illuminated CCD array:
 - cheaper

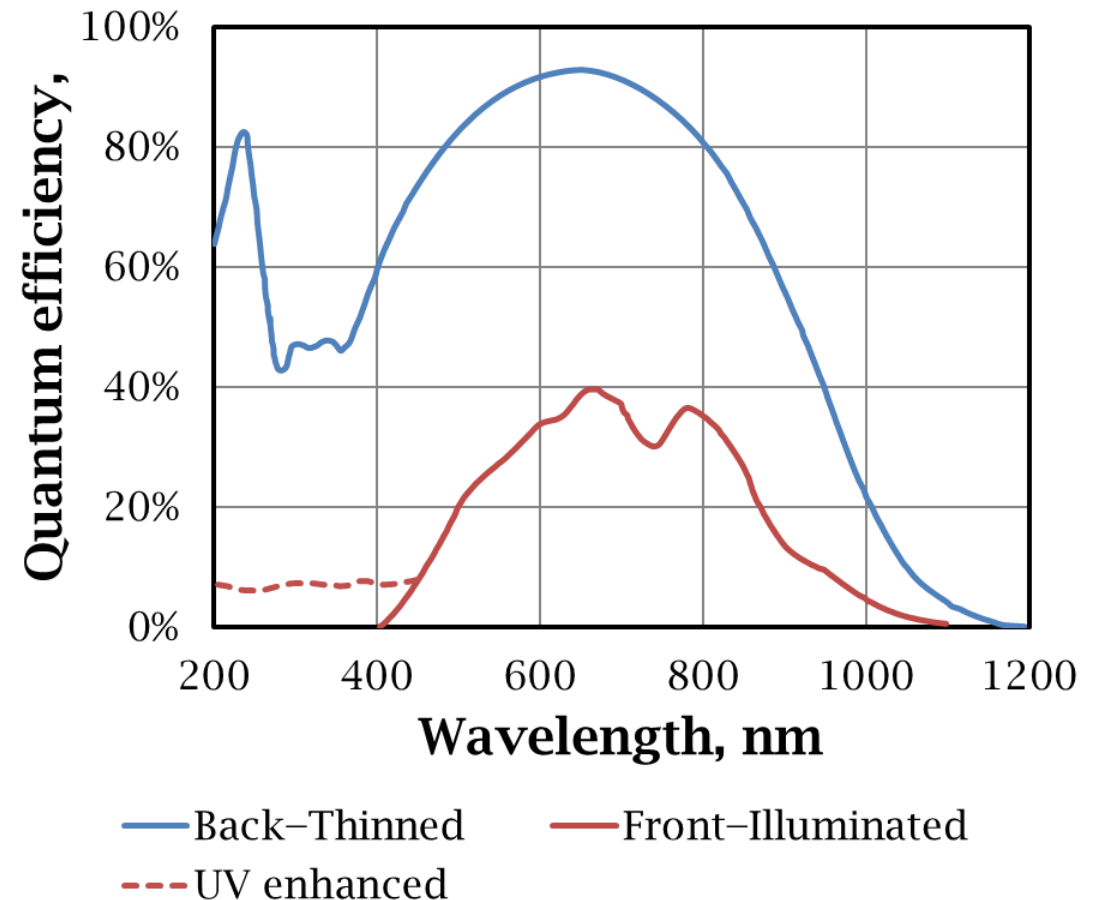

Imaging Systems

Imaging Systems

An imaging measurement system uses a 2D detector to measure multiple points of light simultaneously. This simulates the human visual experience of a display, capturing the entire display at once to evaluate and compare millions of points of data.

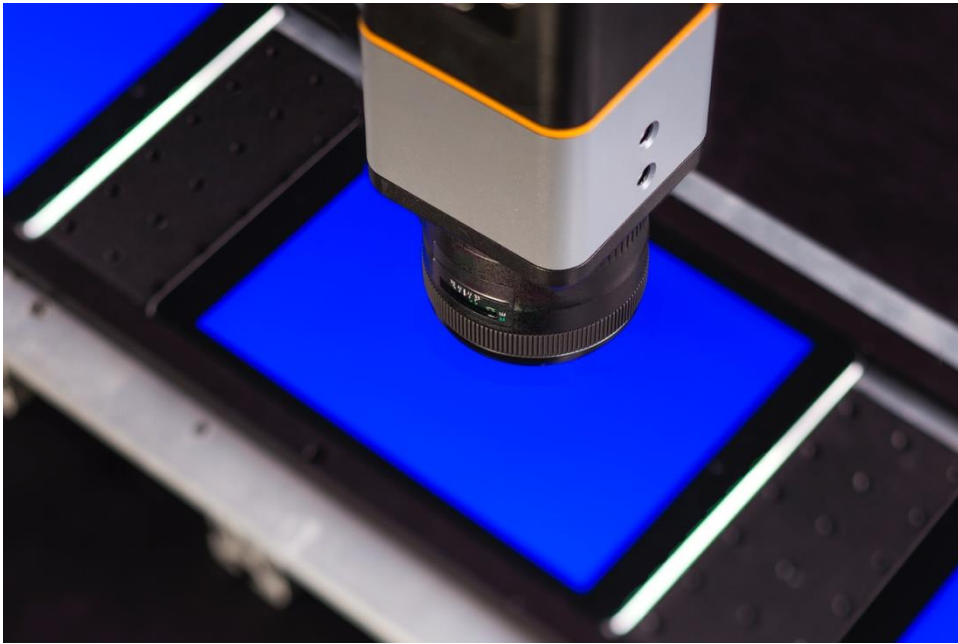

Imaging system performing visual inspection

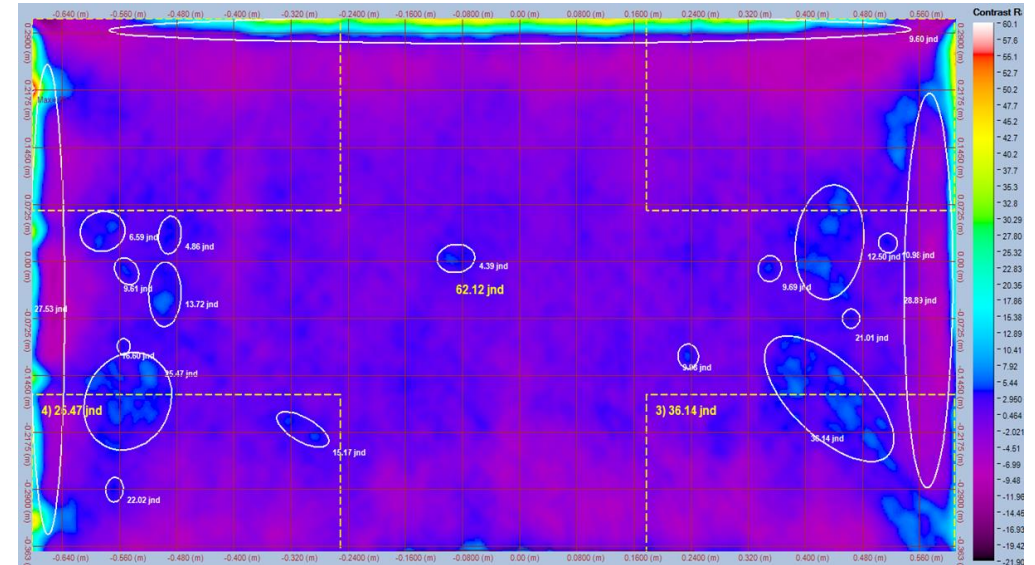

Measurement image captures entire display area

Imaging System Benefits

Imaging in display metrology enables:

- Contextual evaluation: uniformity, gradient, contrast, mura, distortion
- Location, identification, and severity of defects (pixels, lines, blobs)
- Simultaneous measurement of multiple regions of interest (LED arrays, pixels, subpixels)
- Determining dimensions, distortion and focus quality (projection displays)
- Performing advanced analyses with multiple analyses possible per image captured
- I-series and Lumitop X series shown to the right.



Example high-resolution imaging colorimeters

Imaging System Components

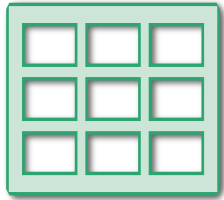

1. Image Sensor



2. Filter (photopic or colorimetric)



3. Optics (lens)

Image Sensors

Rectangular matrix of photodetectors, each capturing photons to be converted to digital signal. Common sensor types are CCD (charge-coupled devices) and CMOS (complementary metal-oxide semiconductors).



Example imaging photometer

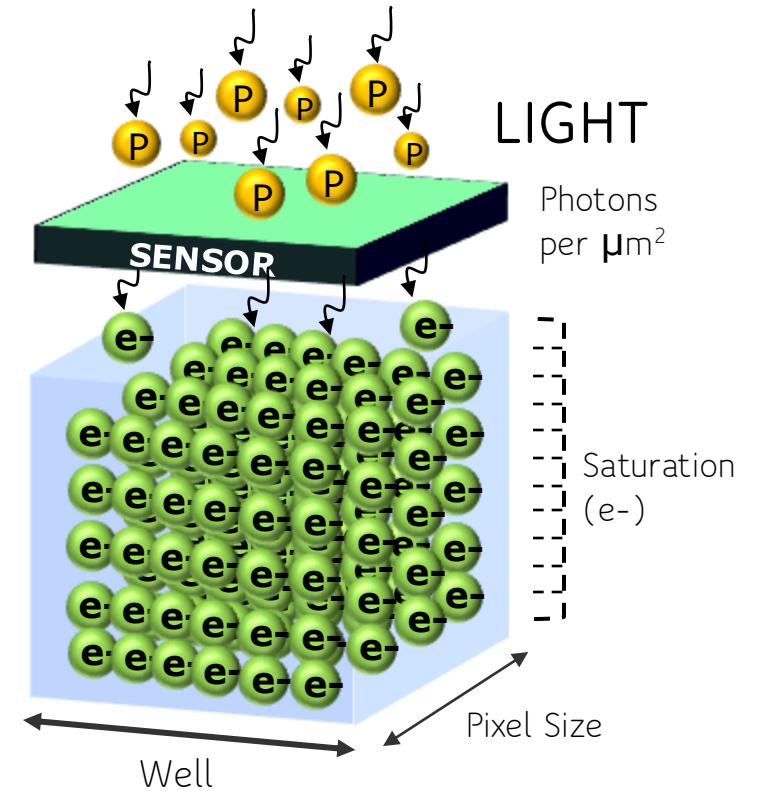
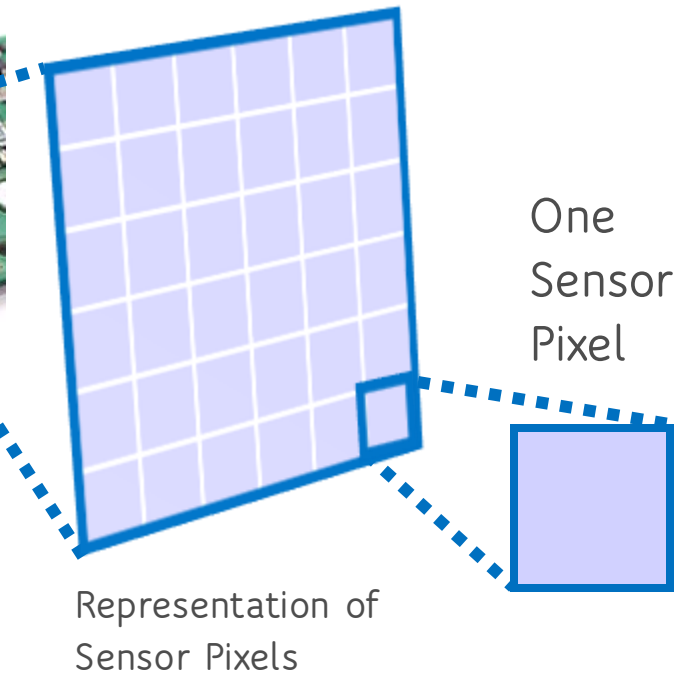

Sensor Characteristics: Resolution

Resolution – The number of pixels in an image sensor determines the number of pixels (discrete points of data) within an image, which determines the ability to distinguish detail in an image.

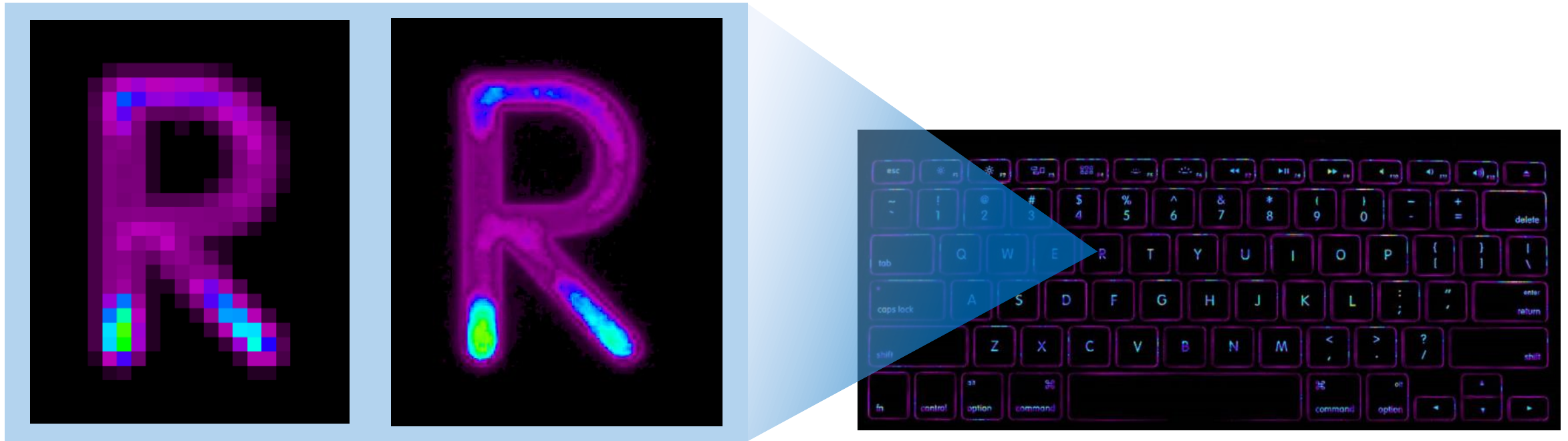

1MP Resolution

29MP Resolution

Sensor Characteristics: Sensor Size

Size – The size of the sensor’s active photo-sensing area determines the imaging system’s field of view when working with a lens with a given focal length.

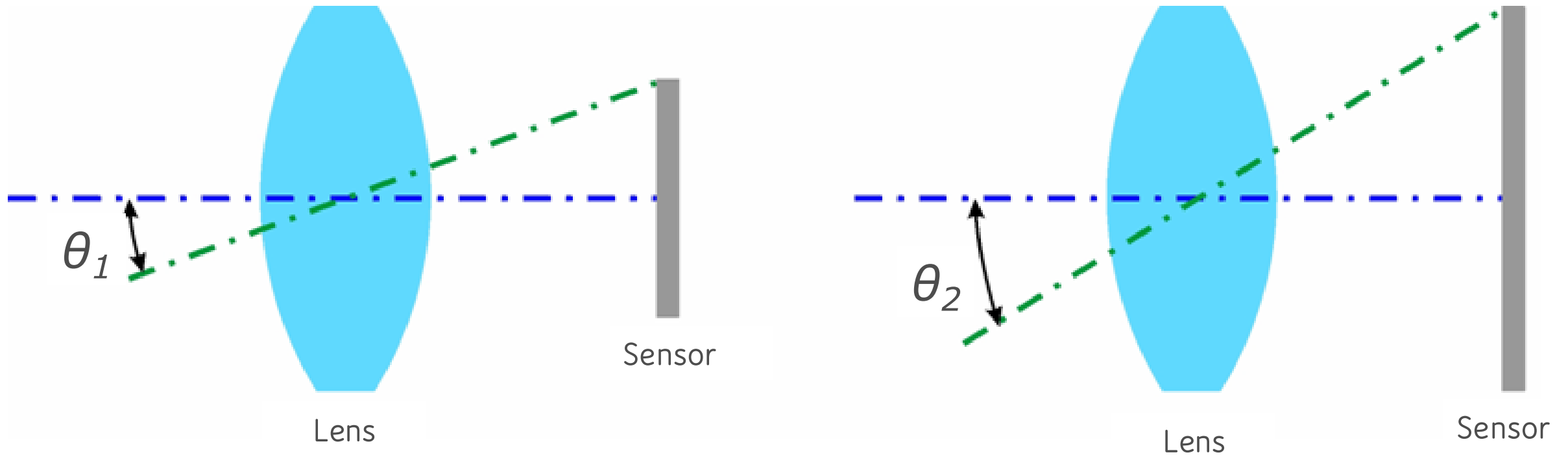

Color Filters

Color Filter Wheel System

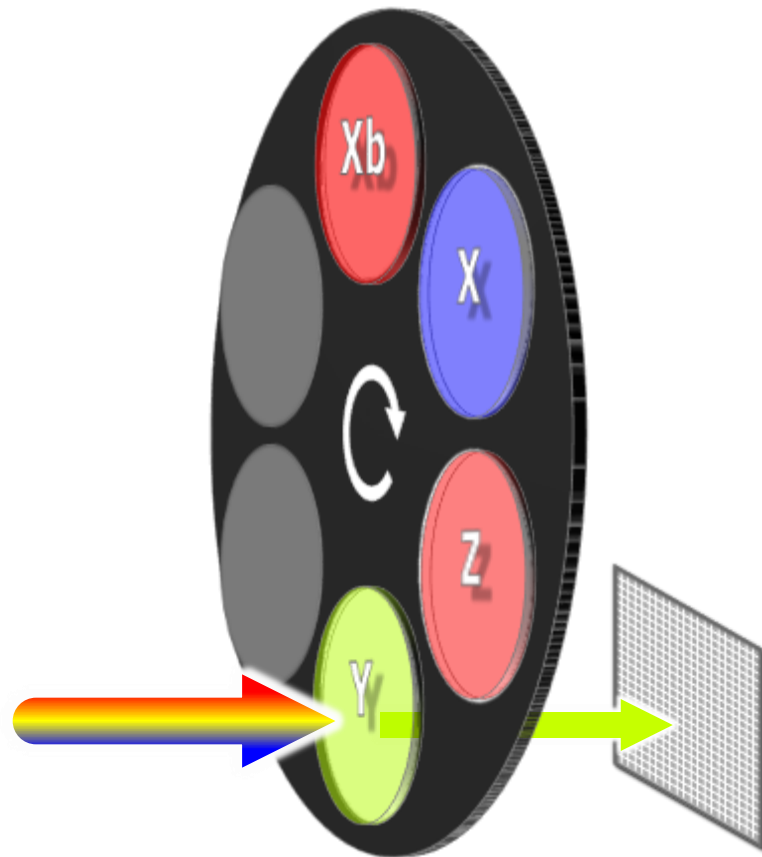

Bayer Pattern System

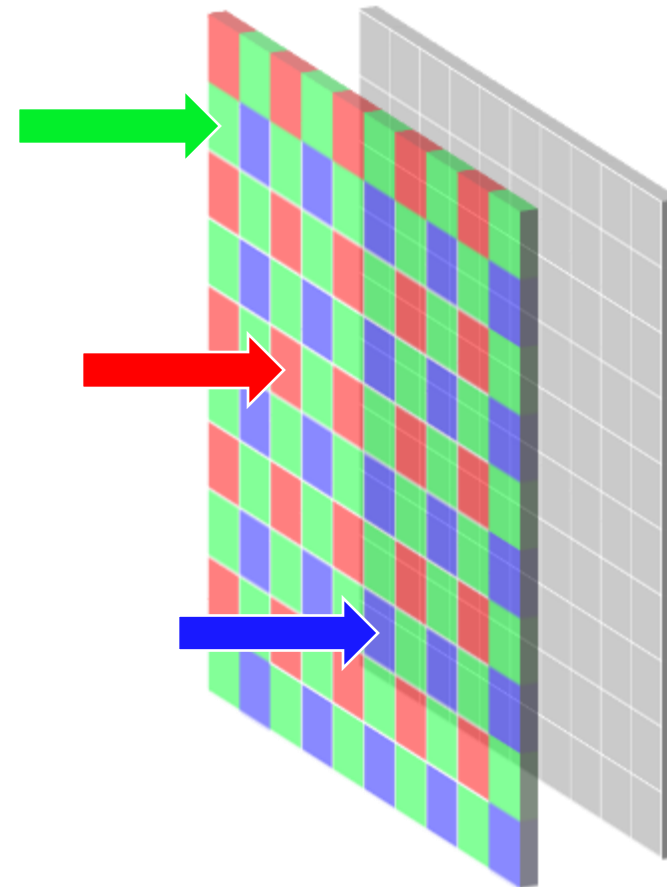
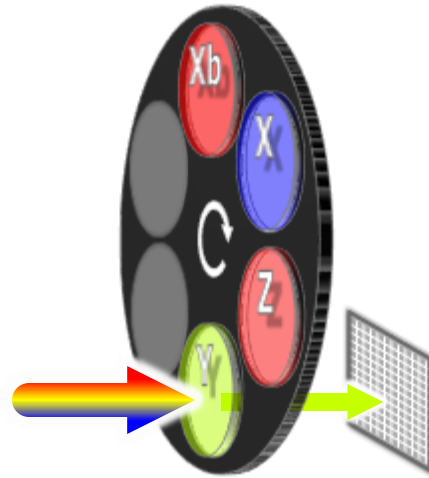
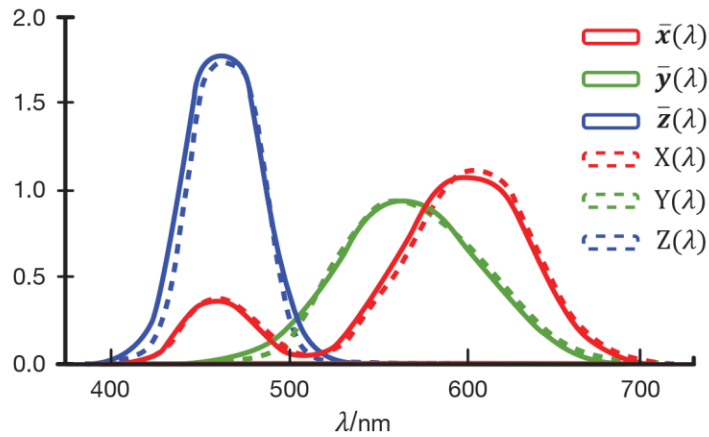

Image-based Color Measurement



12-matrix
element
calibration

System Response

$$\begin{bmatrix} X \\ Y \\ Z \end{bmatrix} = \begin{bmatrix} a_{11} & \epsilon & \epsilon & a_{14} \\ \epsilon & a_{22} & \epsilon & \epsilon \\ \epsilon & \epsilon & a_{33} & \epsilon \end{bmatrix} \begin{bmatrix} X \\ Y \\ Z \\ Xb \end{bmatrix}$$

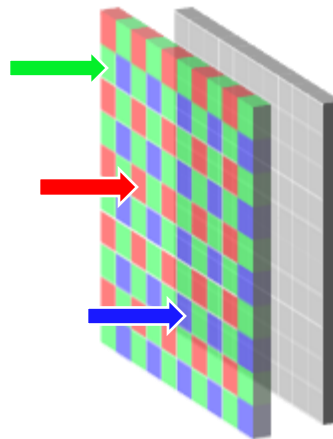
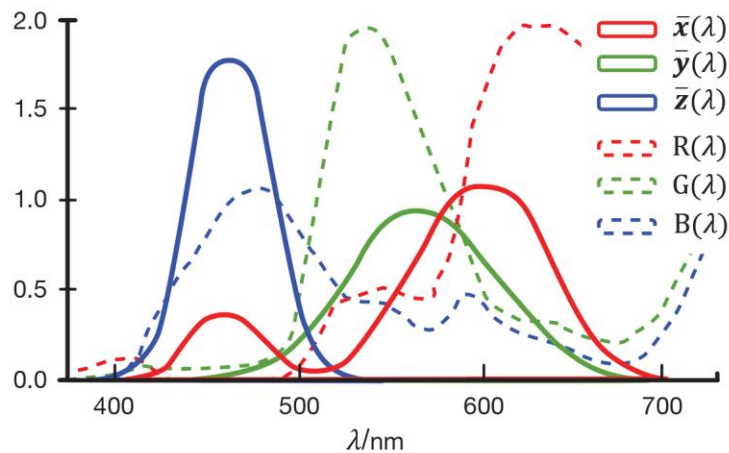

9-matrix
element
calibration

$$\begin{bmatrix} X \\ Y \\ Z \end{bmatrix} = \begin{bmatrix} a_{11} & a_{12} & a_{13} \\ a_{21} & a_{22} & a_{23} \\ a_{31} & a_{32} & a_{33} \end{bmatrix} \begin{bmatrix} R \\ G \\ B \end{bmatrix}$$

Optics

Imaging Lenses

- Selected to achieve a specific field of view (object size)
- Focus settings for different object distances
- Aperture settings for different light levels and depths of field
- Functions:
 - Ensure imaging quality enables resolution at sensor pixel level
 - Ensure repeatability/accuracy if focus or aperture is changed
- Typical options:
 - Wide-field-of-view lenses for large-screen TVs
 - Narrow-field-of-view lenses for mobile displays
 - Microscope lenses for microdisplays



Example standard lenses (top) and microscope lens (bottom)

Specialty Optics

Application-Specific Lenses

- Example: AR/VR Lens
 - Entrance pupil (aperture) at front of lens
 - Wide field of view
 - Replicate human pupil in headsets

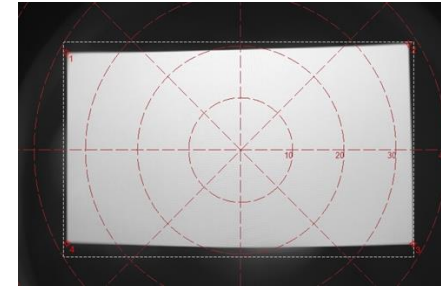

Projection Measurement Systems

- Test illumination by measuring light cast on a screen

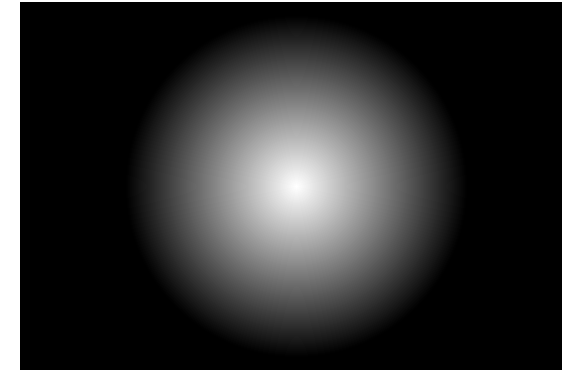
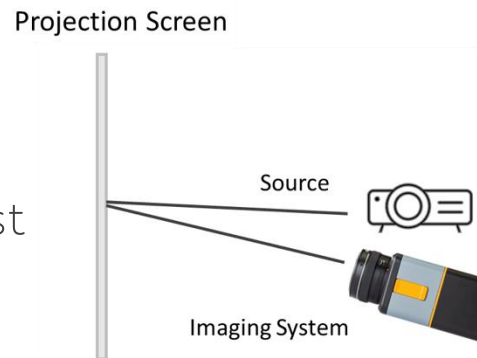

Angular Imaging

- Example: Fourier Optics
 - Redirects angular light to 2D plane
 - Creates polar plots of source output

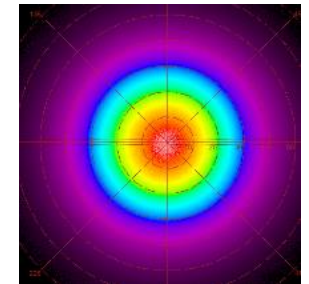
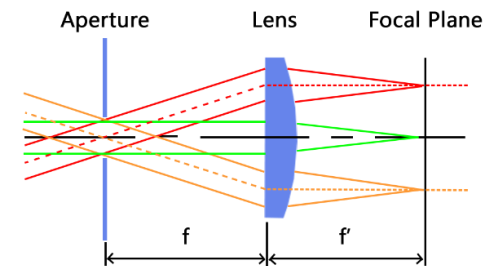

Example AR/VR lens (top), projection measurement (middle) and Fourier optic lens (bottom)

Fusion: Spectroradiometry + Imaging

Why combine imager & spectroradiometer?

Accuracy:

- Spectroradiometers are considered most accurate
- Accuracy independent from DUT-DUT spectral variations
- Low accuracy-loss when transferring to 2D image

Speed:

- Simultaneous capture of all color channels
- Simultaneous capture of spectrum and image
- Flicker diode to sync to display refresh rate

Scope:

- Able to perform quality assurance and parameter adjustments with one device. E.g.:
 - Luminance uniformity, color uniformity
 - Mura analysis
 - Gamma adjustment
 - Gamut adjustment
 - Flicker measurement

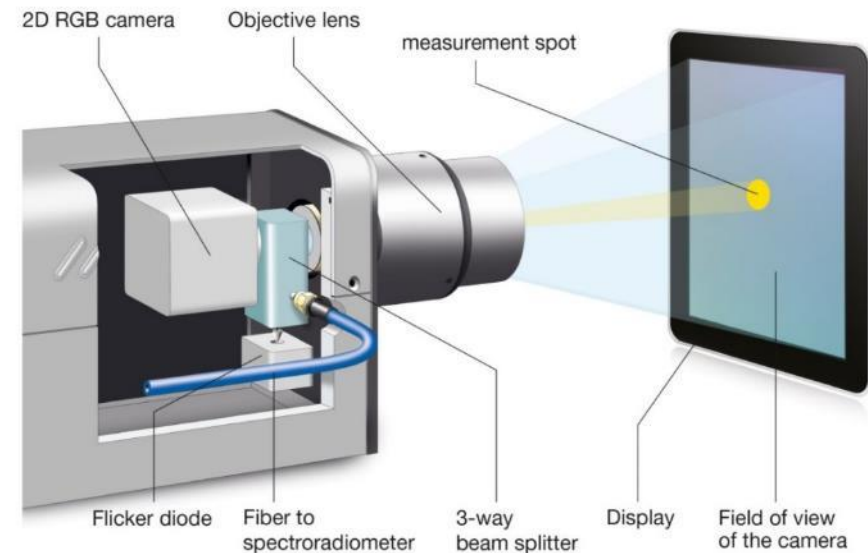
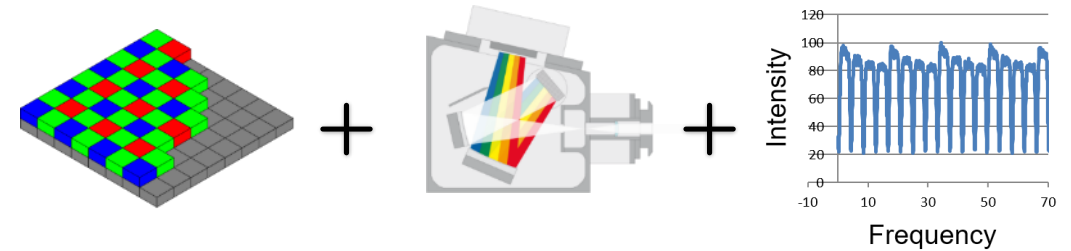

Calibration

Accuracy & Precision of a Measurement

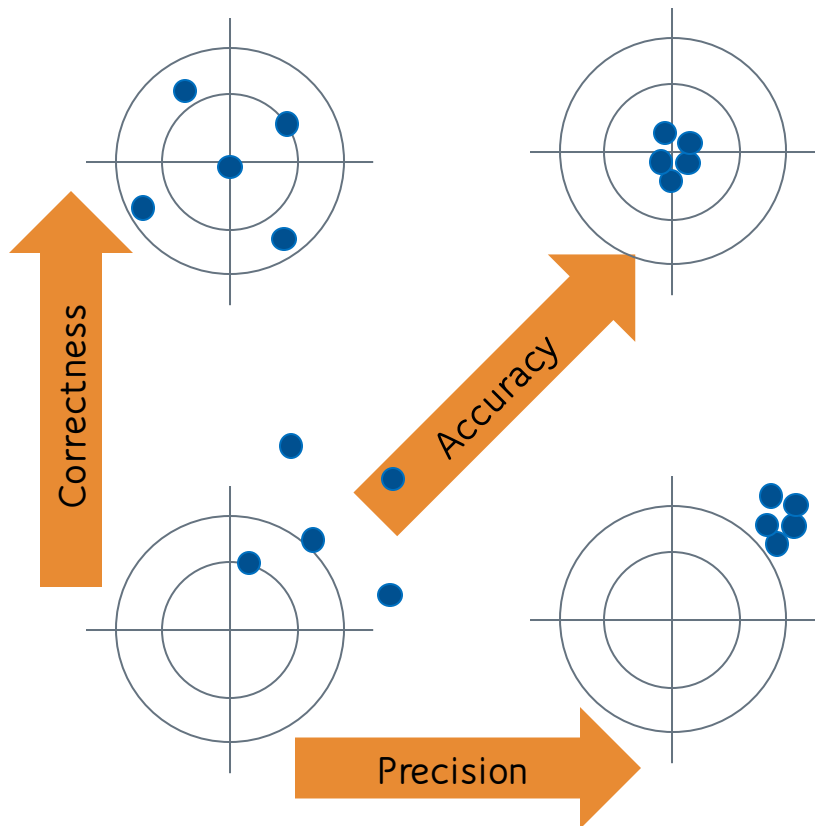

▲ Precision:

- Spread of measurement results is low

Precision is (under ideal conditions) a property of the device!

▲ Correctness:

- Mean value conforms with correct value

Measurement uncertainties along calibration chain determine correctness!

▲ Accuracy:

- Measurement is precise AND correct

Spectroradiometer: Wavelength Calibration

- Ensures correct assignment of detector pixels to wavelength
- Use spectral lines as reference
 - Hg, Xe, Ar- lamps and HeNe-laser
- Atomic lines do not need recalibration (physical standards)

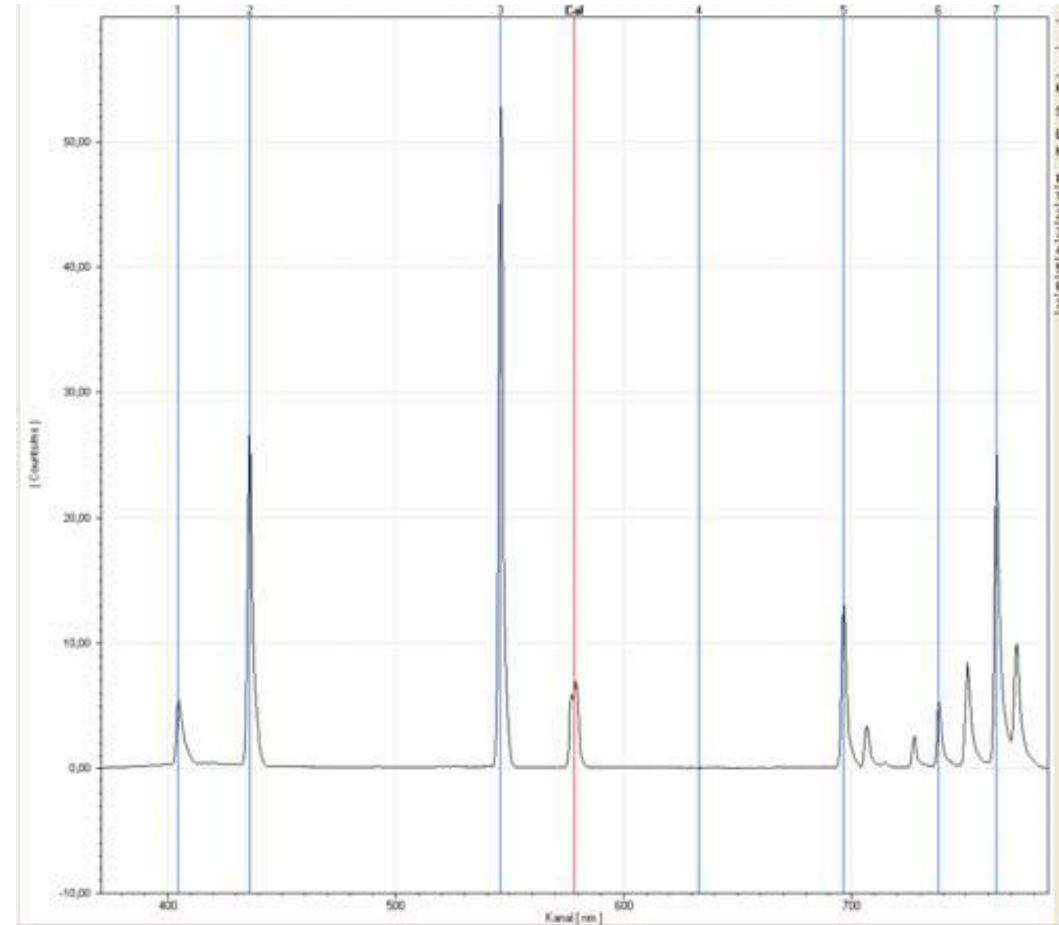

Spectroradiometer: Spectral Calibration

- Use of a traceable standard (e.g., for radiance)
 - The correct spectral calibration is crucial for the accurate color coordinates
 - Measure raw data with calibration standard and compare to tabulated reference values
- Correction factor for each pixel to establish radiometric scale

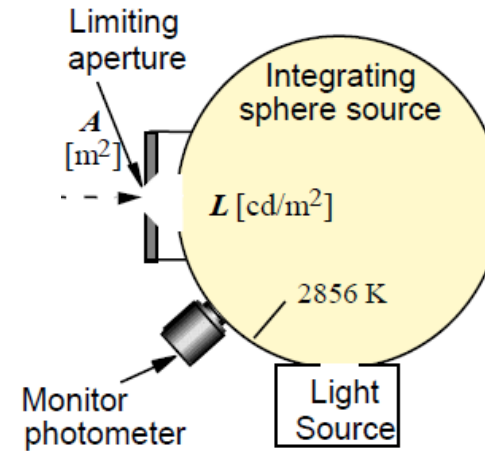

Example for the realization of a (spectral) radiance standard

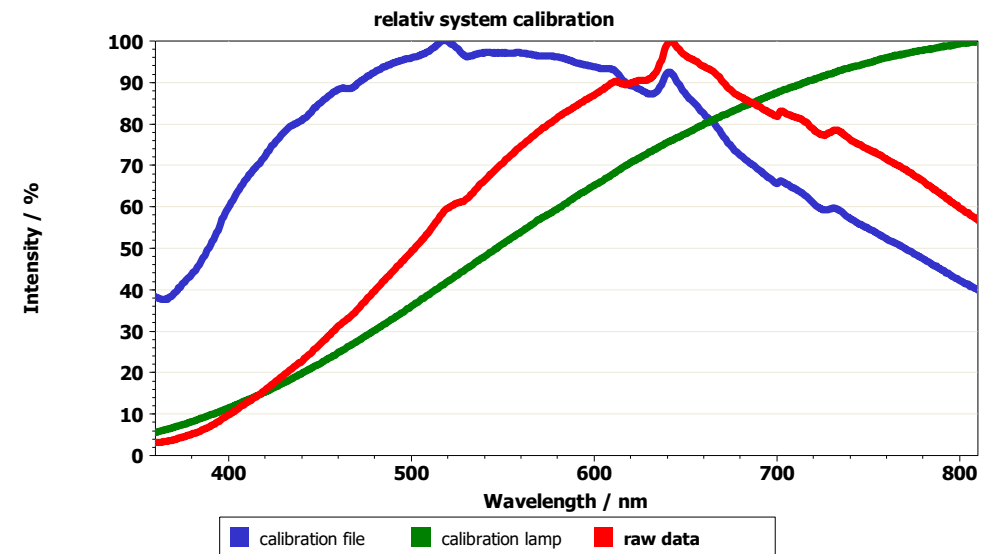

Absolute Calibration

For establishing traceability, calculation of measurement uncertainties, and suppression of systematic measurement errors, it is often beneficial to use a standard calibrated for spectrally-integrated quantity for setting the absolute scale.

Might be the same standard as for spectral calibration. Sometimes it is beneficial to have an integral scale.

→ Correction for integral reading to cd/m^2

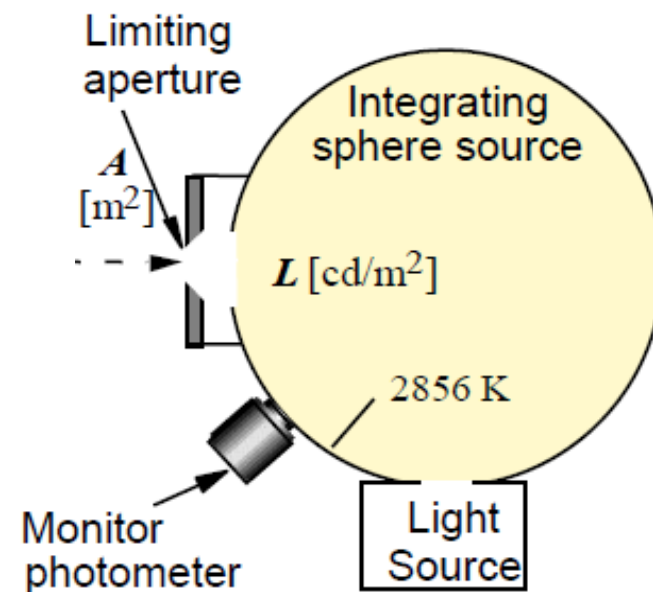

Calibration of Imaging Light Measurement Device

- Typical camera calibration includes:
 - defect pixel correction
 - dark current and flat field correction
 - Geometric undistortion
- Color calibration:
 - Assumption: Displays use additive color mixing
 - Calibration valid for known spectra of display
 - For higher accuracy: principle of similarity. Calibrations should use a similar type of display for calibration as for the measurement.

Examples of typical variation in display spectra

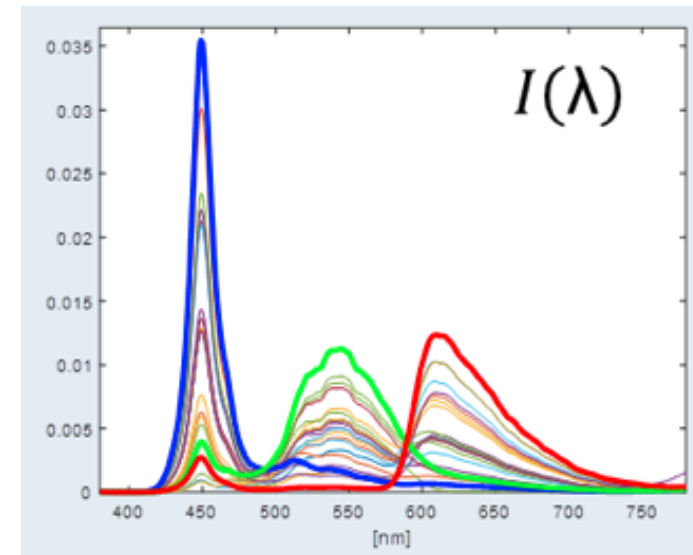

Maintaining System Alignment

GOLDEN SAMPLE

- Use of a “reference station” to create golden samples. Reference station typically equipped with spectroradiometer. Golden samples to align the factory stations.
- Align all stations on factory floor
- Monitor drifts in reference station
- Golden sample stability is crucial



AUDIT

- Factory stations have traceable calibration to measure absolute values. An audit source with absolute reference values is used to verify accuracy periodically.
- Align also on different sites / supply chain
- Traceable to the factory floor & traceable check
- Stability of audit source is crucial



III. Measuring Specific Display Characteristics

QUANTIFYING DISPLAY OUTPUT, DETECTING DEFECTS, AND
CHARACTERIZING PERFORMANCE

Mura & Defects

Types of Defects

- **Mura** - Japanese for “uneven”; describes an area of non-uniform brightness or darkness at any point in the display.
- **Dots** - Stuck-on, dead, or dim pixels; contaminant particles at any point in, on, or under the display glass.
- **Lines** - Connected rows of dead pixels, or sections of dim or bright pixels; extend the vertical or horizontal area of the display.

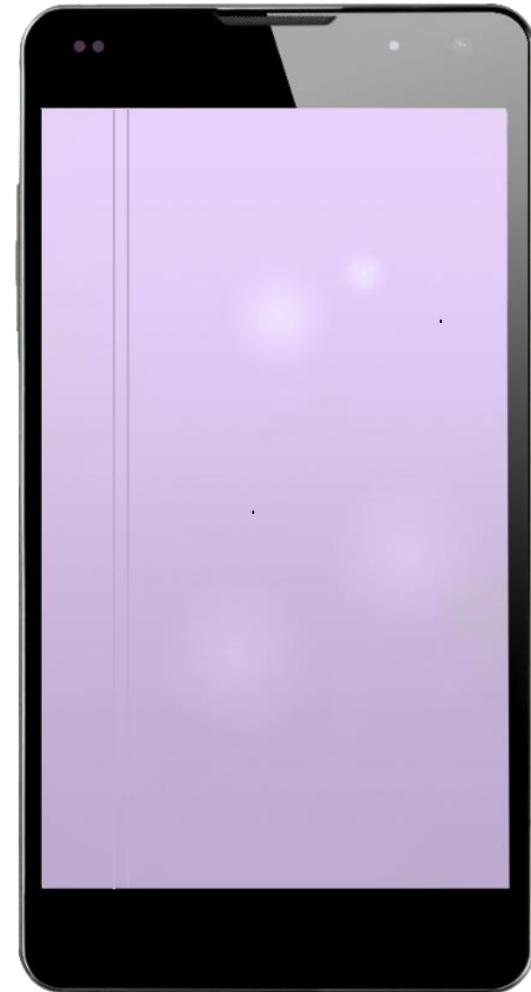

Mura

Non-uniform areas; bright or dark blobs across the display.

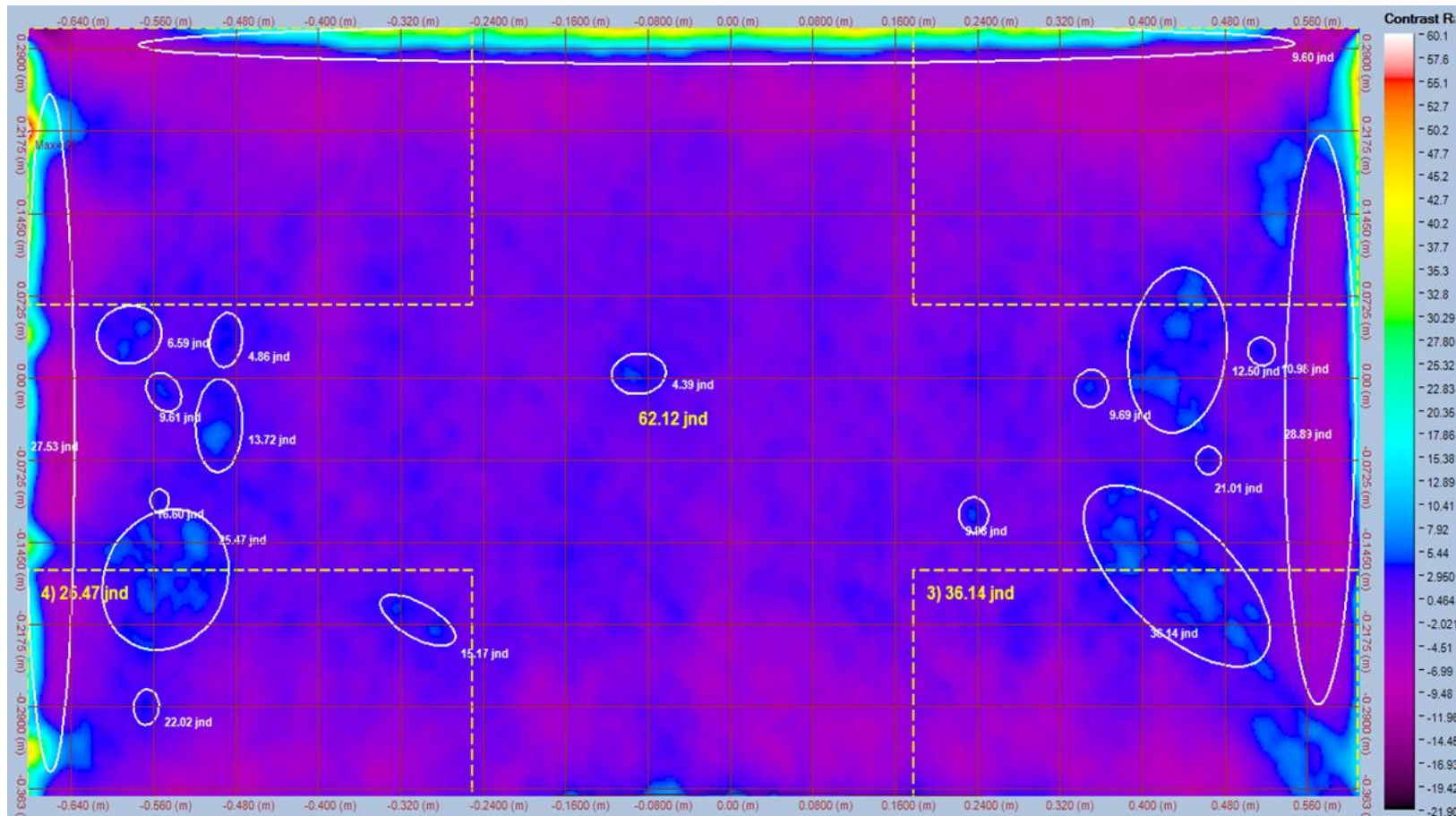

Types of Mura

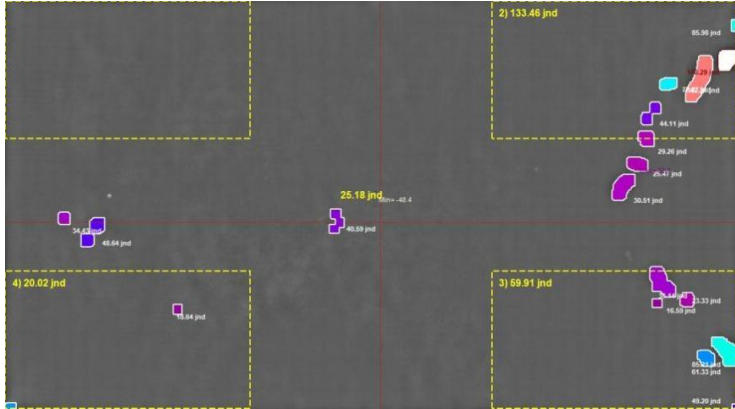

Black Mura

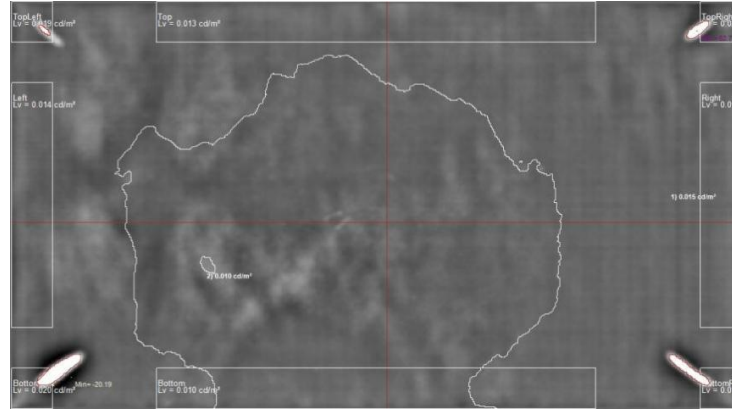

Butterfly Mura

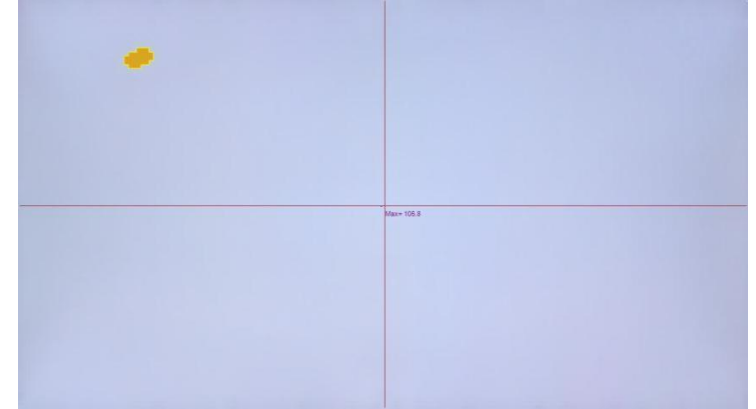

Color Mura

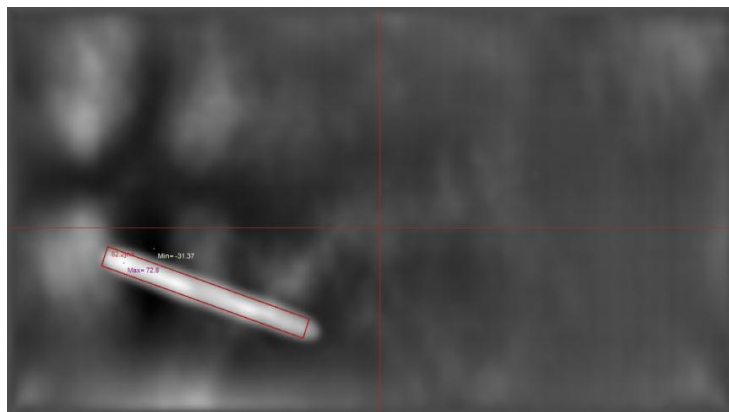

Diagonal Line Mura

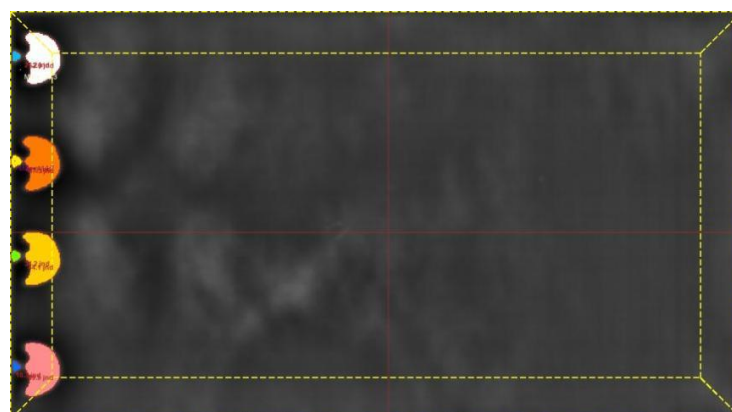

LED Mura

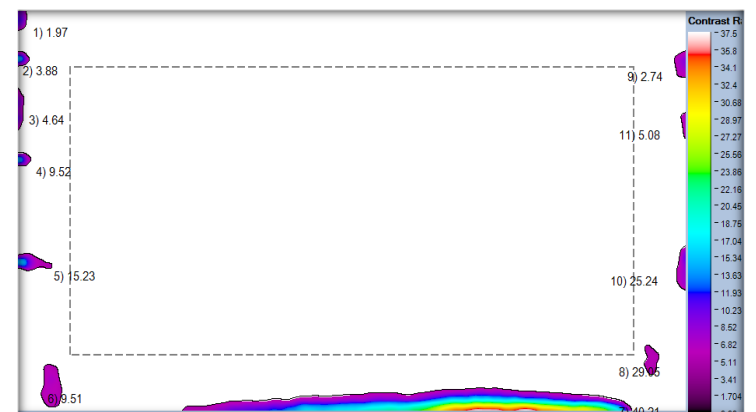

Light Leakage

Dot Defects

Stuck-on (hot), dead, or dim pixels; contaminant particles.

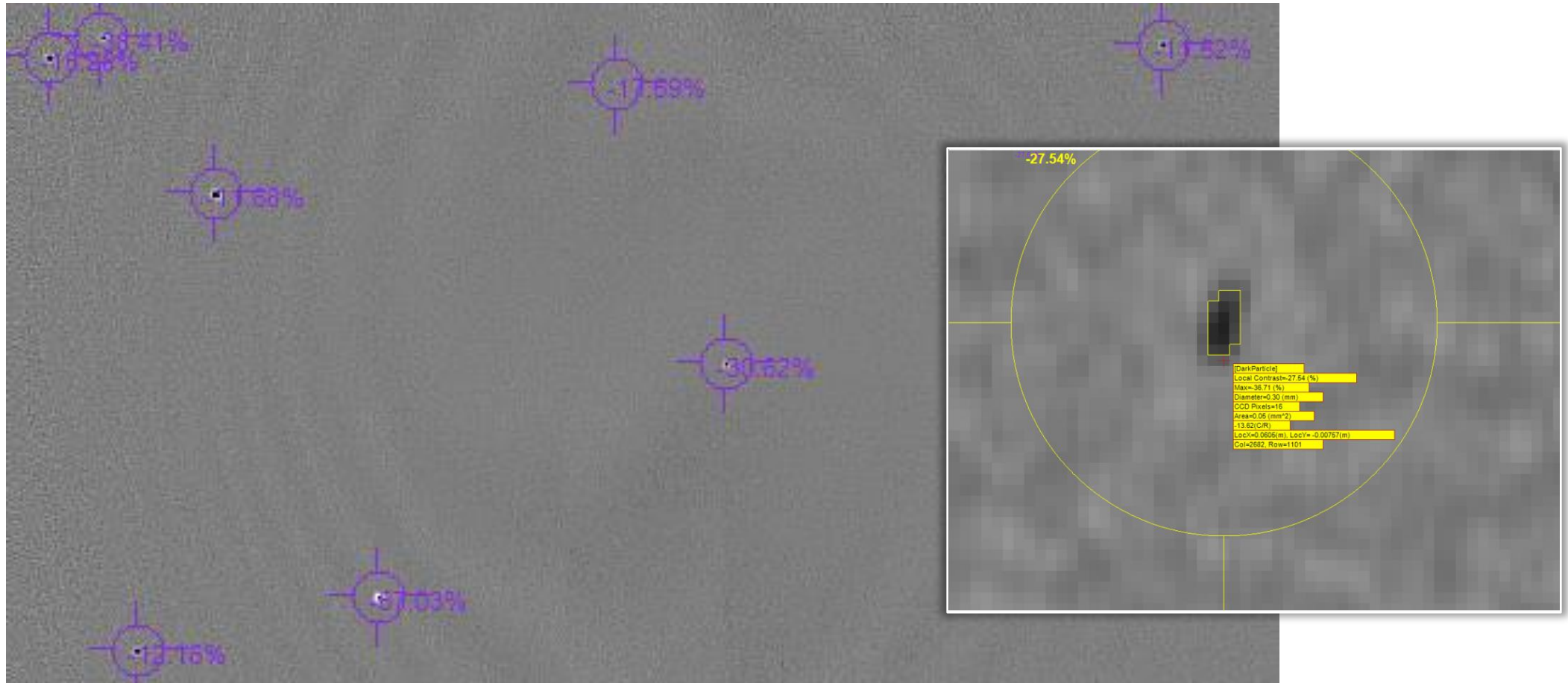

Line Defects

Sharp, extended blemishes that usually span the entire width or height of the display and only exist in the vertical or horizontal directions.

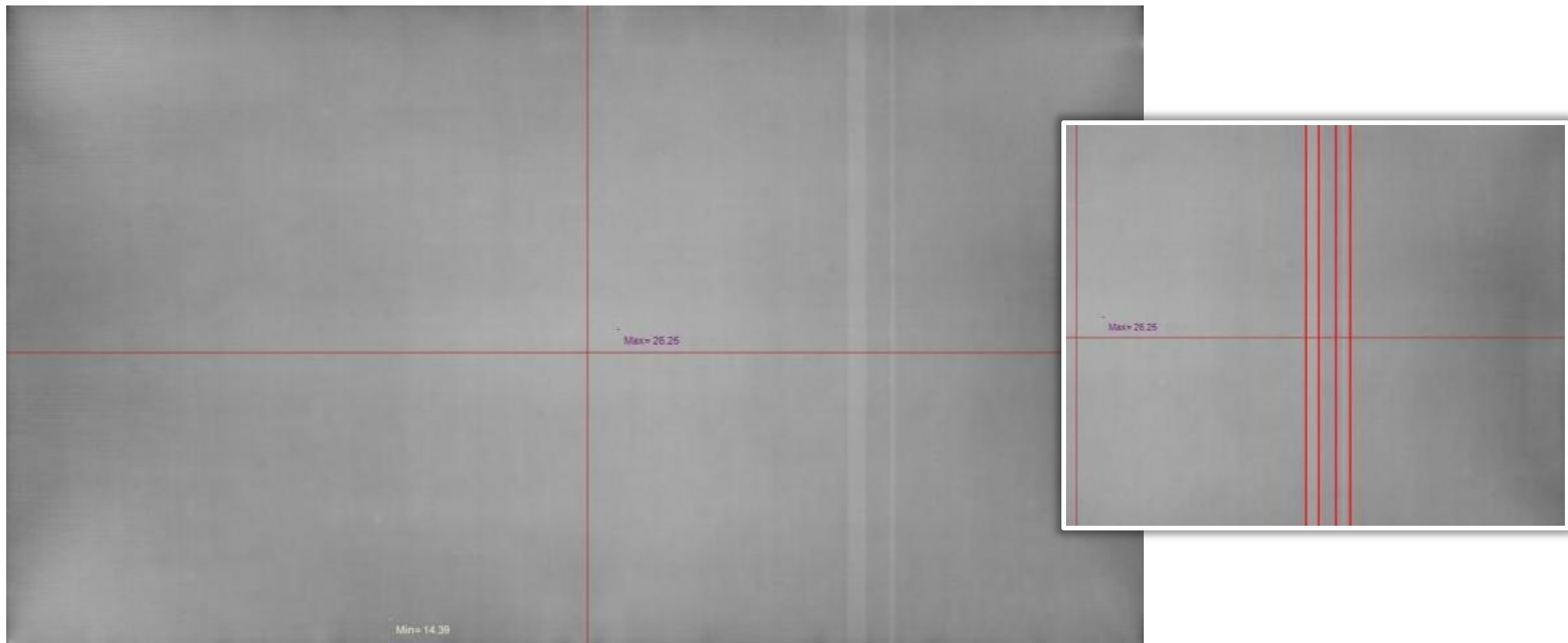

Prerequisites for Defect Detection

1. Imaging System
2. Sufficient Resolution
3. Image Preparation
 - a. Crop to Active Display Area
 - b. Remove Moiré



Example imaging photometer

Crop to Active Display Area

From the measurement image, isolate the active display to maximize measurement and reduce detection of false defects from background or bezel.

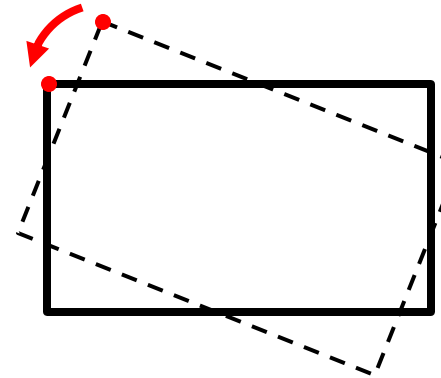
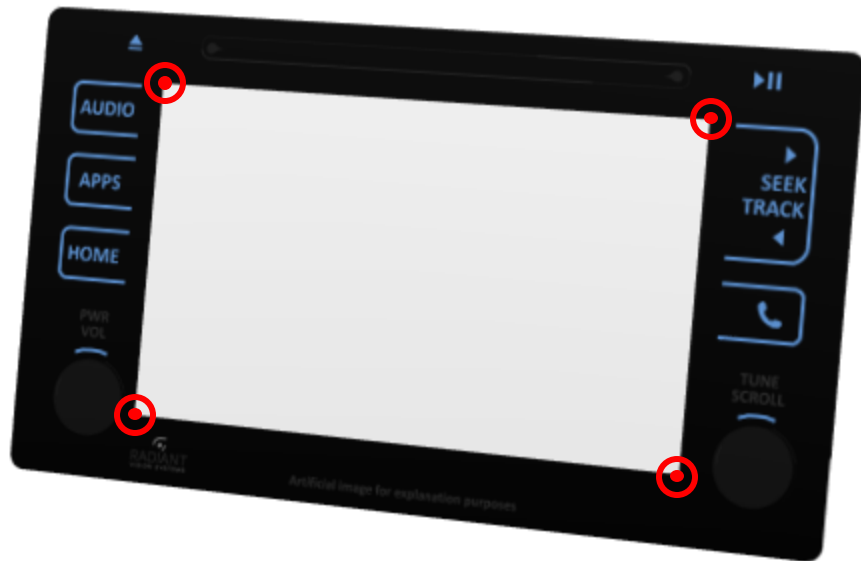

Correct the display orientation

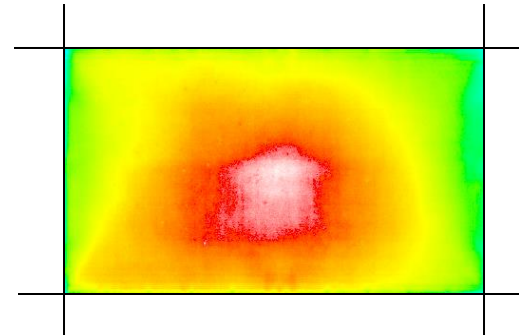

Crop to the active display area

Remove Moiré

Moiré - An effect of aliasing between the pixels of an image sensor array and the pixels of a display being imaged upon it.

- Moiré appears at regular frequencies, so it can be isolated and removed in the frequency domain.
- Moiré artifacts can be removed with image processing software.

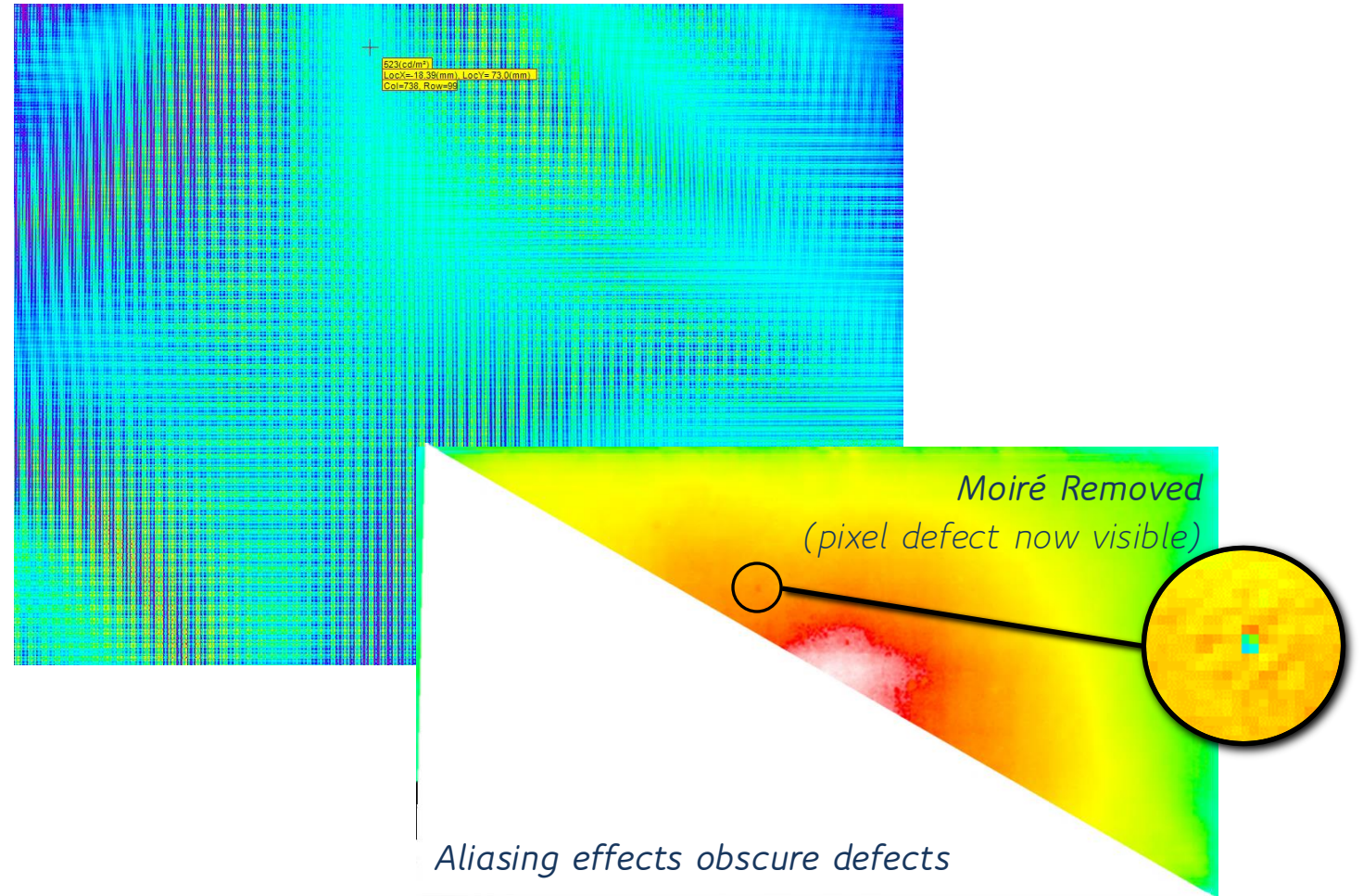

JND Demonstrated on Black Pattern

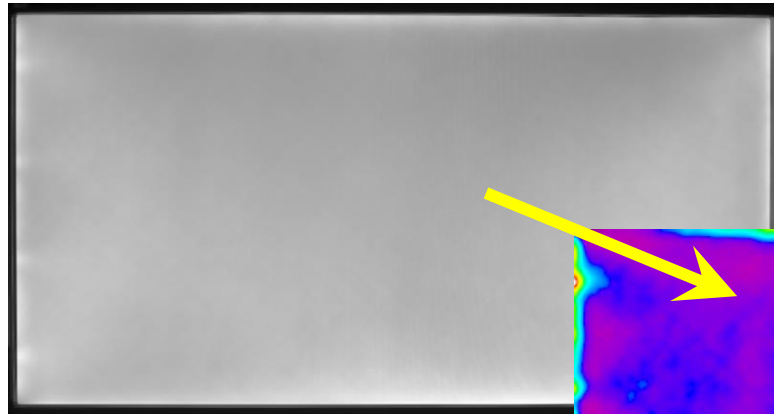

1. A black pattern test image is captured by the imaging system

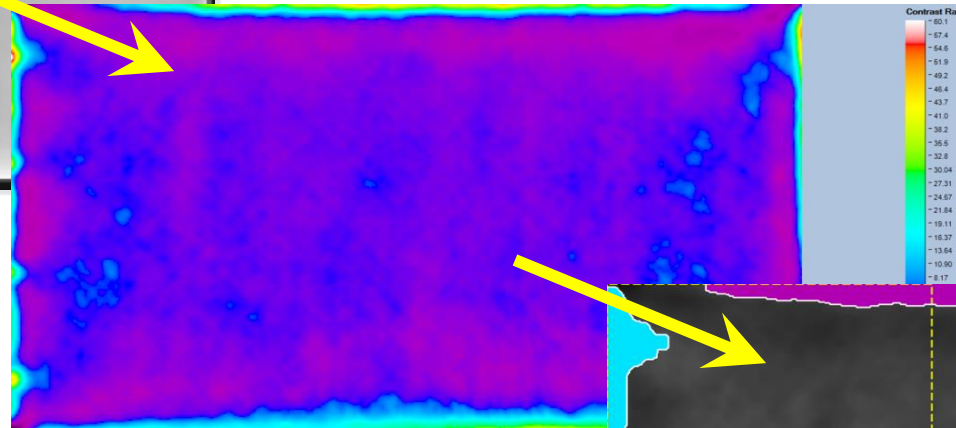

2. "Just noticeable" defects are quantified and compared with pass/fail criteria

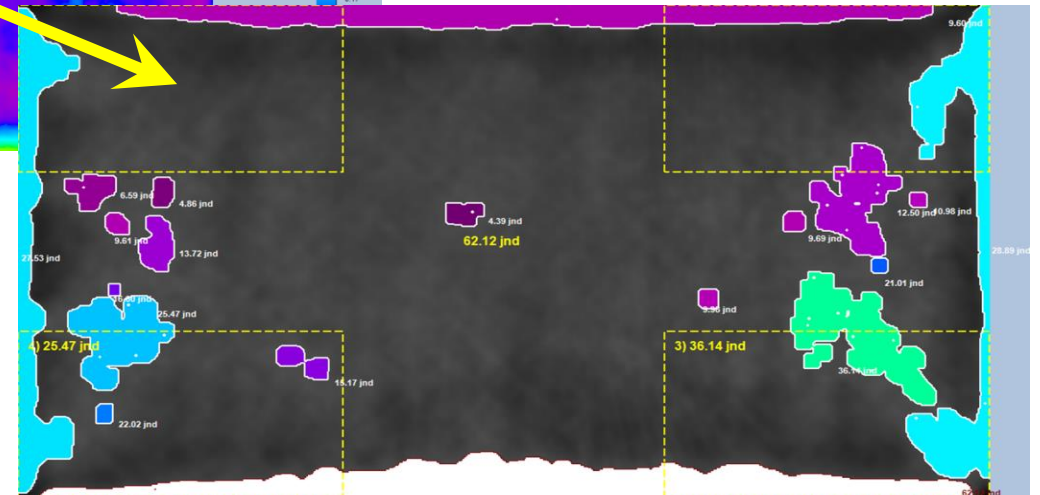

3. Defects identified in software are displayed in a Local Contrast image

Pass/Fail Based on Mura Type & Severity

In a fully automated display inspection, custom tolerances could be set for mura type and severity.

Process steps:

1. Isolate and identify types of mura
2. Score the different mura using JND (e.g.: 4, 7, 8)
3. Pass/fail displays based on type or severity of mura

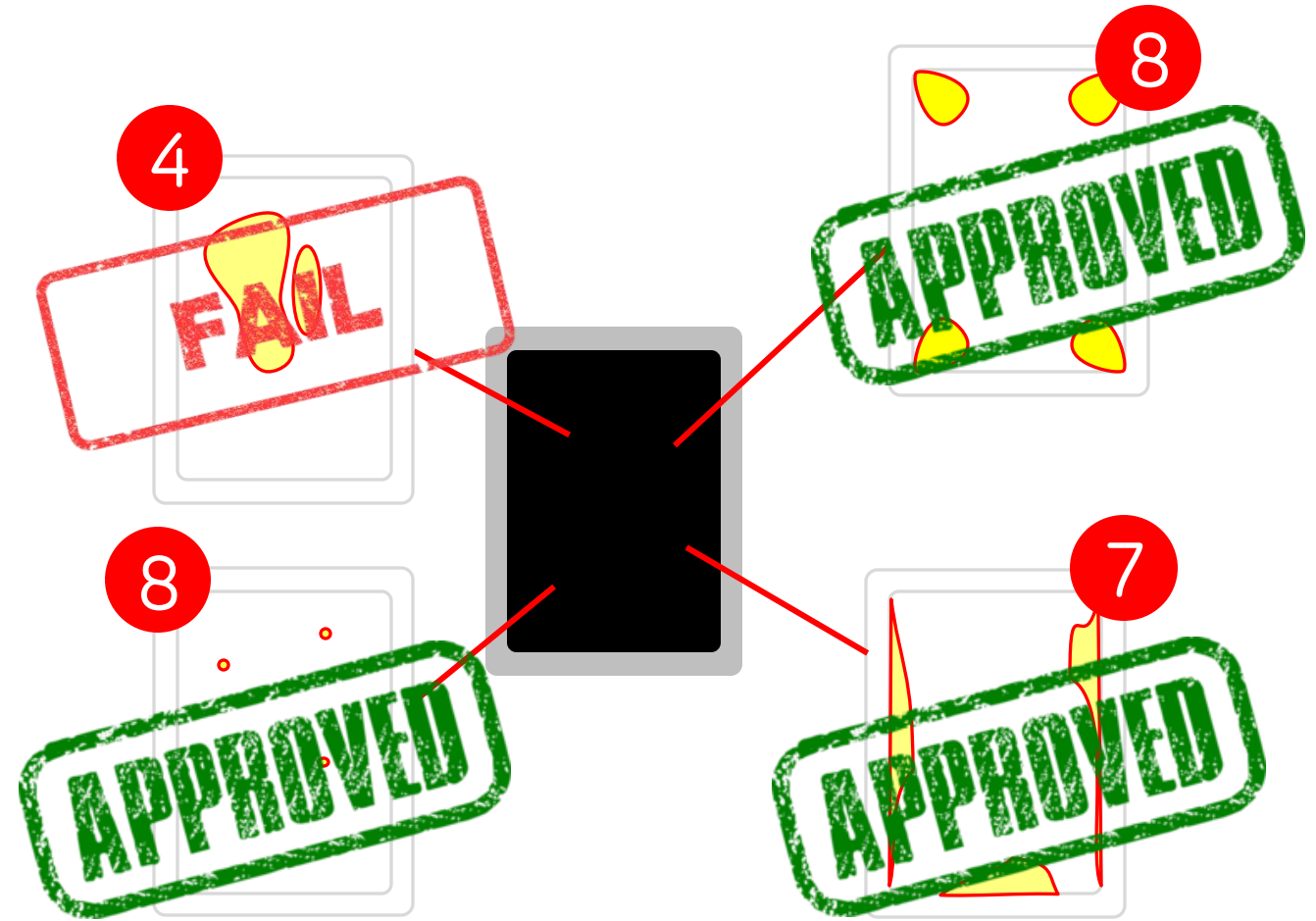

Dot & Line Analysis

Dot and line defects are isolated by local contrast or local gradients.

Defects classified by geometric properties:

- Size, length, eccentricity, orientation

Pass/fail based on:

- contrast or gradient level (*photometric*)
- size of defect, number of defects, and location of defect (*geometric*)

Moiré removal image processing is very important for detecting dot and line defects.

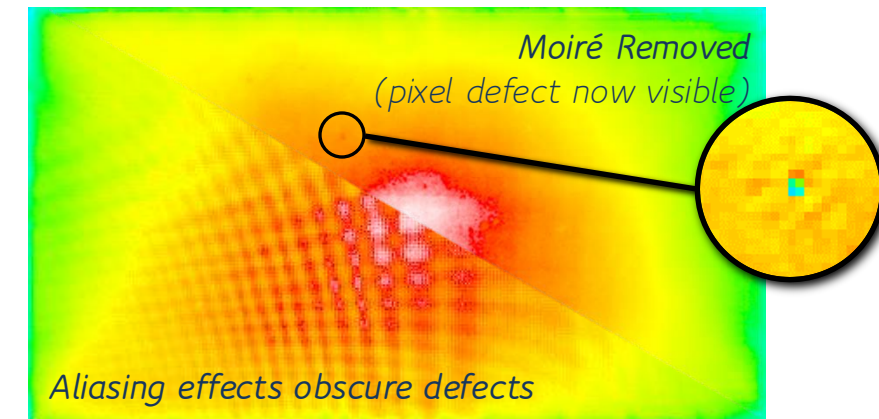
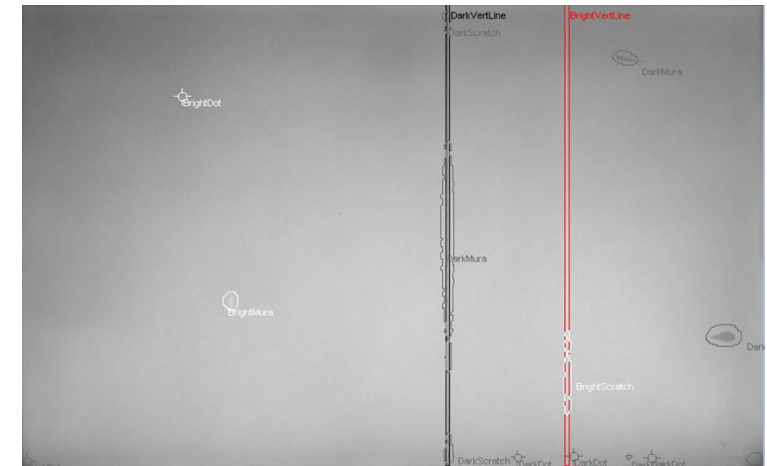

Pixel-Level Measurement

Pixel-Level Measurement

Goal: Measure the output (luminance or color value) of each pixel or subpixel in a display.

Challenge for Measurement System:

- Isolating each pixel or subpixel using registration methods.

Optimal Registration Method:

- Ensures accuracy and repeatability of measurement.
- Eliminates crosstalk between ROI.

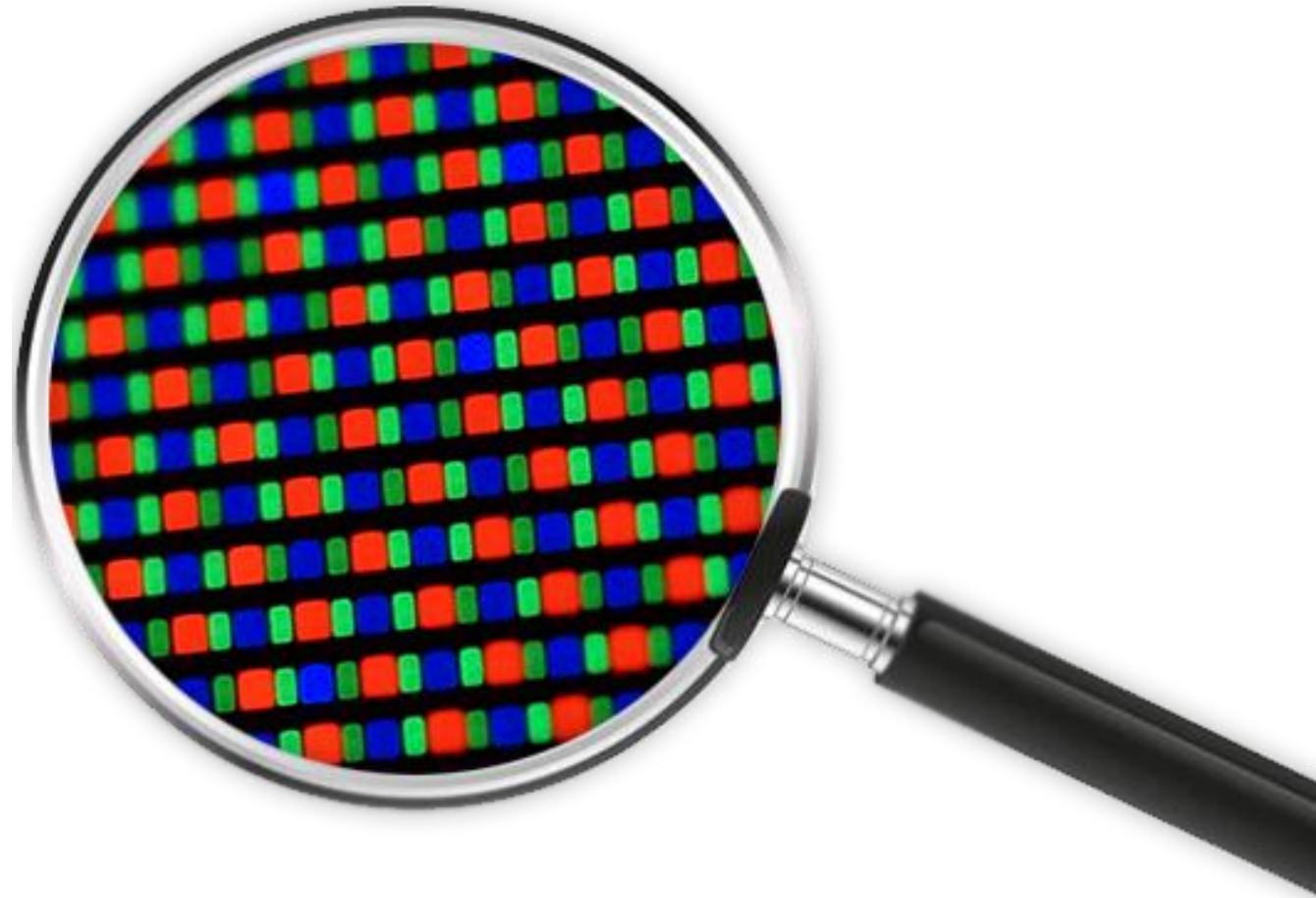

Pixel-Level Measurement

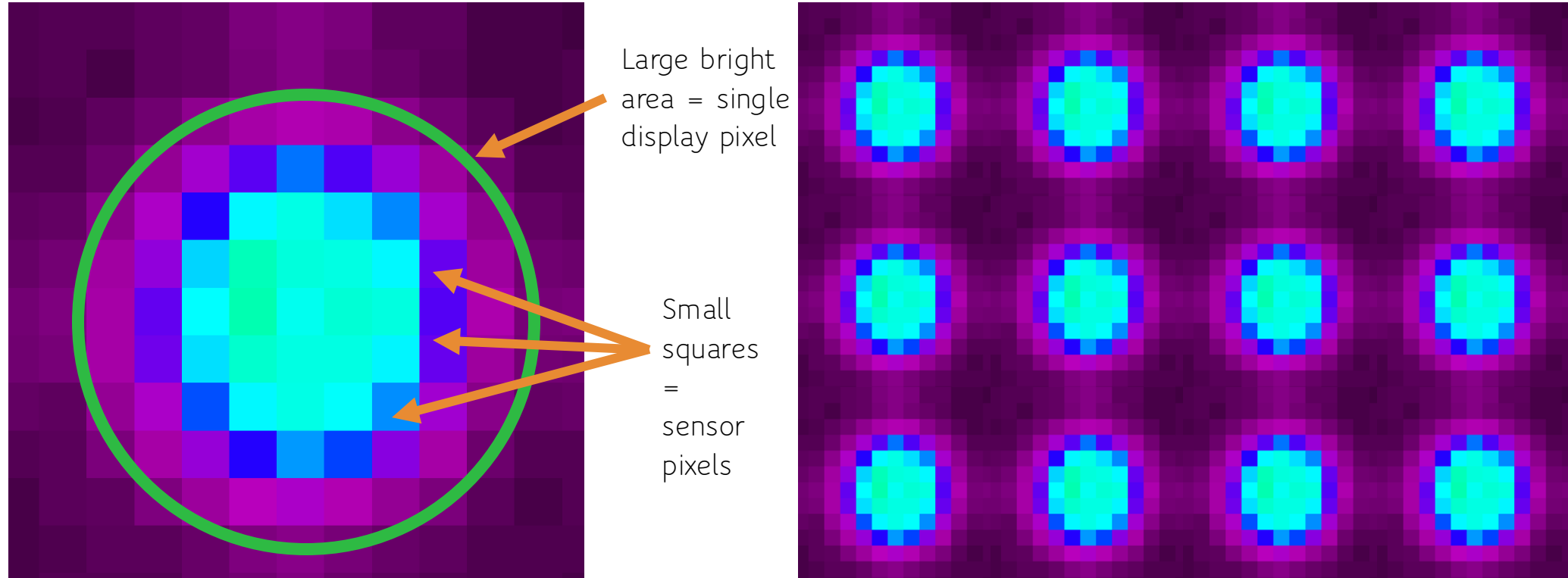

Sufficiently Isolate Each Pixel
(*Pixel registration*)

Capture Accurate Values for Each Pixel
(*Pixel measurement*)

Pixel Registration Method 1: Fixed Grid

Fixed grid method:

1. Align the display and imaging system
2. Using display characteristics, create ROI grid

Advantages

- Simplicity of software processing

Disadvantages

- Requires extremely accurate & repeatable alignment of display and imaging system

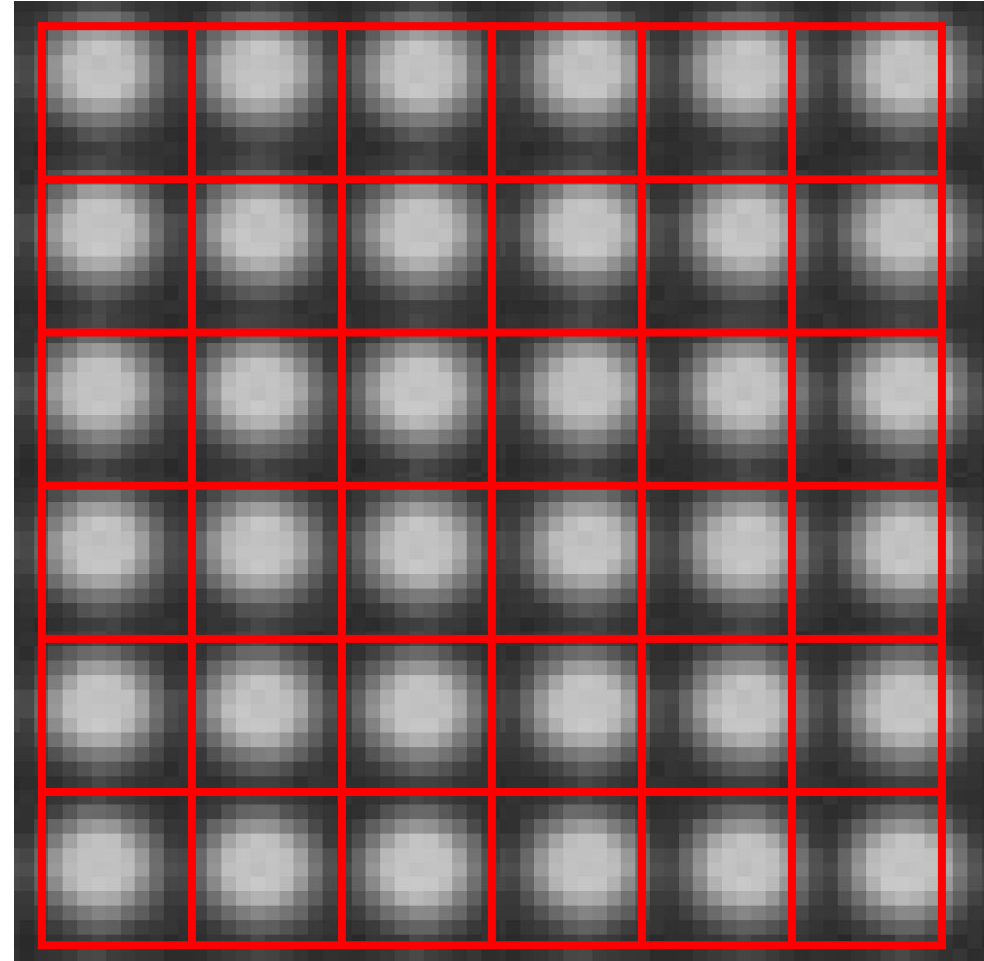

Pixel Registration Method 2: Active Registration

Active registration method:

1. Use image processing to find pixels
2. Create ROI around each pixel

Advantages

- Improved tolerance for display and imaging system alignment

Disadvantages

- More difficult image processing
- Risk of error due to pixel defects (hot / dead pixels in the array)

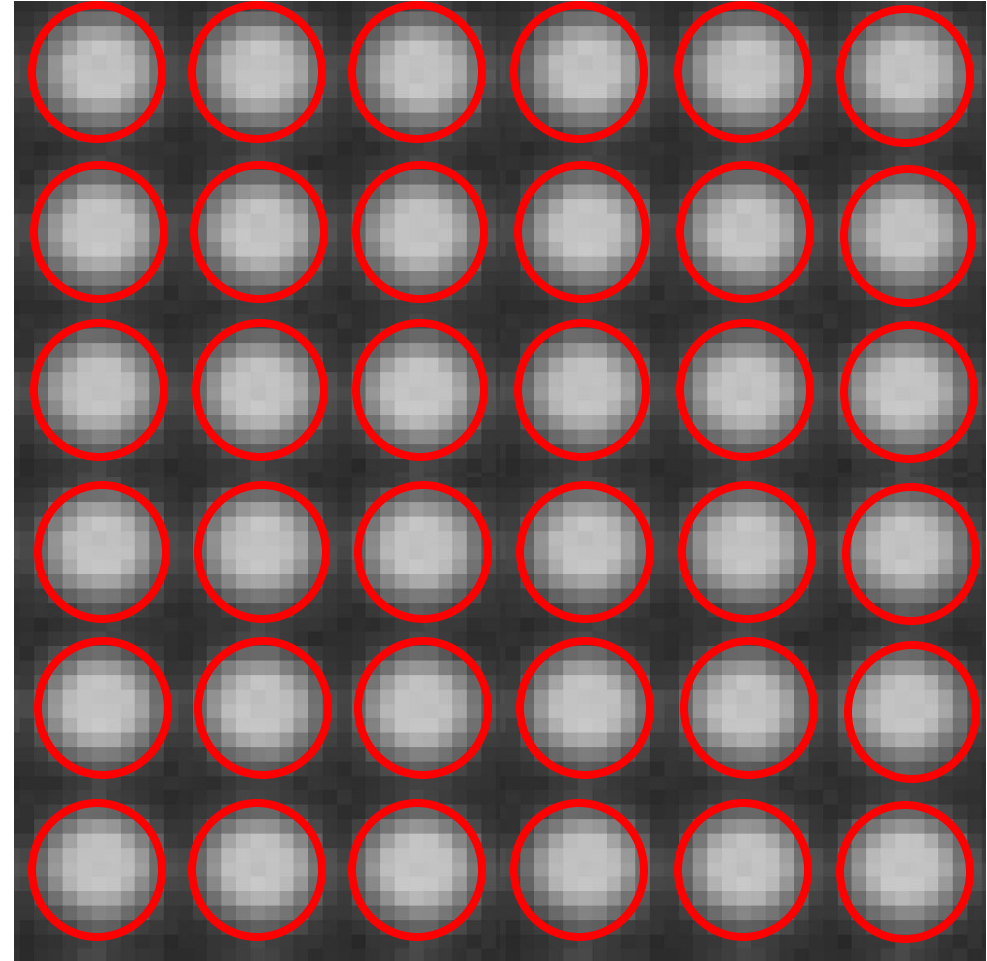

Eliminating Crosstalk

Crosstalk – Light from neighboring pixels that impacts the measurement of a pixel of interest.

Eliminating crosstalk requires optimizing:

1. Resolution
2. Focus
3. Stray Light Control

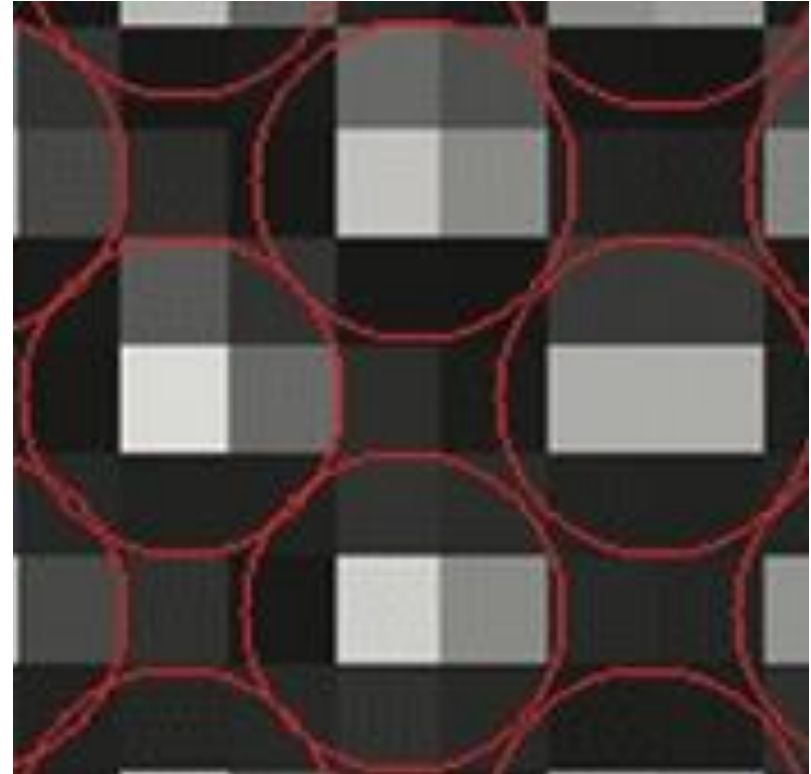

Optimizing Resolution

Testing in Sections

- **Advantages:**
 - Highest possible resolution
- **Disadvantages:**
 - Slowest to measure complete display
 - Movement required to capture complete display
 - Processing needed to accurately combine images of multiple display sections

Spaced Pixel Measurement

- **Advantages:**
 - High resolution
 - Measures complete display in a single image
- **Disadvantages:**
 - Relatively slow to measure all pixels in display
 - Processing needed to combine multiple images of display pixels

High-Resolution, Single-Image Measurement

- **Advantages:**
 - High resolution
 - Measures all pixels in a single image
 - Fastest measurement of complete display
- **Disadvantages:**
 - Requires high-performance sensor, optics, calibrations, and computing power

Testing in Sections



Microscope Lens (20X zoom)

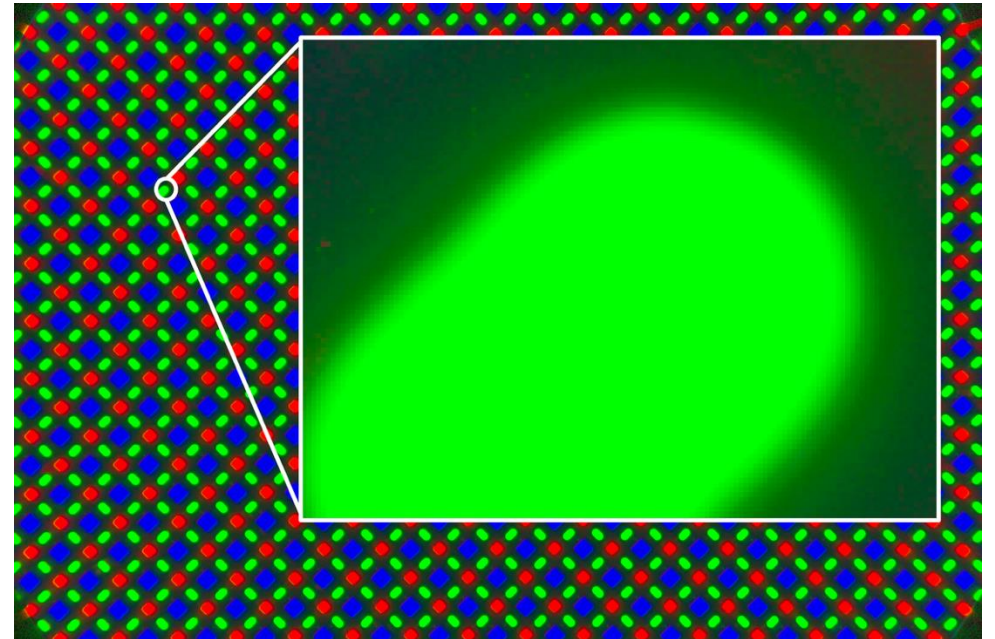

OLED Phone Display
61MP Sensor at ~20x magnification

Spaced Pixel Measurement

Measure entire display in multiple images:

- Dot-matrix patterns illuminate subsets of display pixels for each primary (RGB)
- Image each pattern until all pixels are measured

Combine measurements into a single synthetic image

Result: Maximizes image sensor resolution across each pixel for increased accuracy

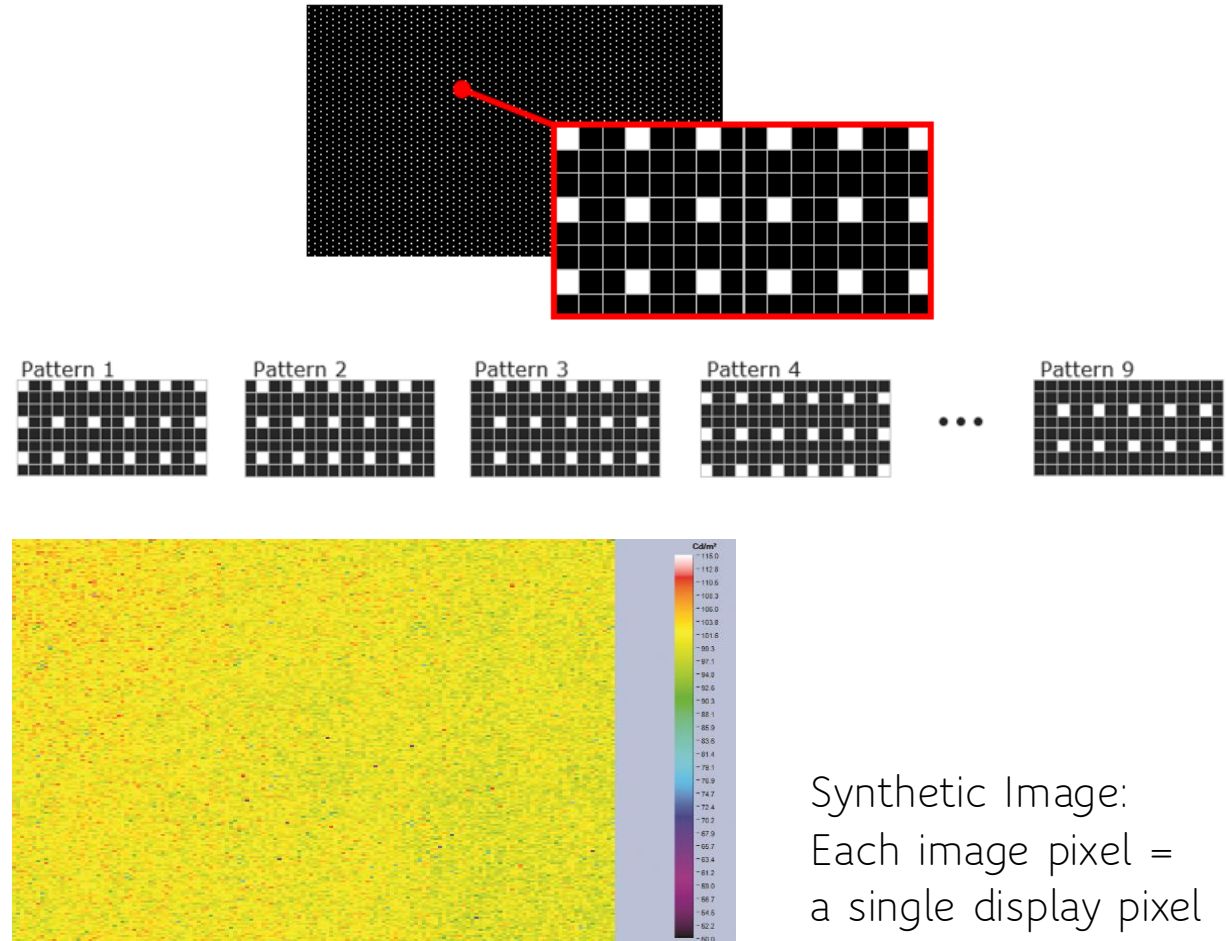

High-Resolution Single-Image Measurement

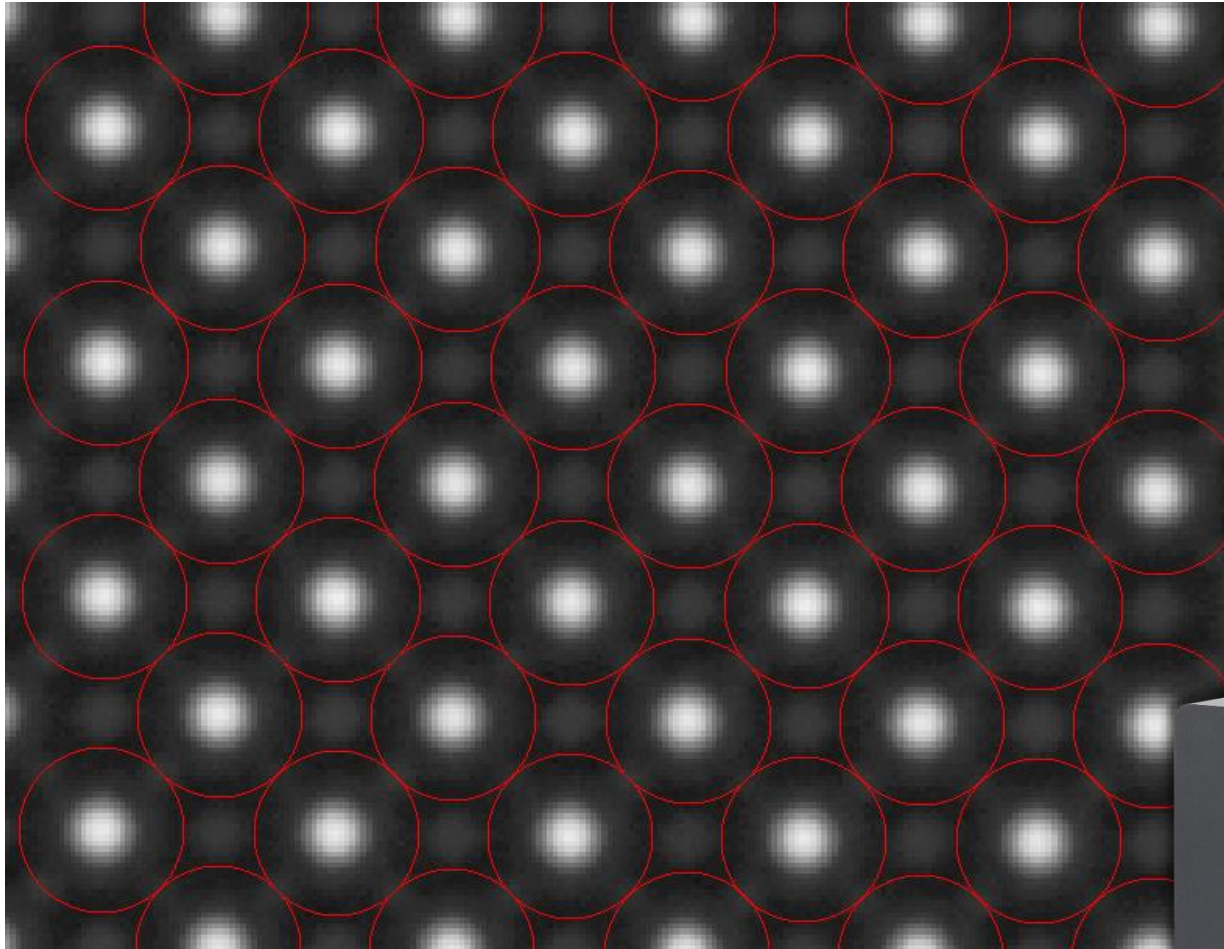

Example measurement image achieving 30 x 30 sensor pixels per display pixel.

Important – Increasing measurement resolution increases demands on the measurement system, requiring higher performance in terms of:

1. Image sensor
2. Optics
3. Calibration
4. Computing power



Example ultra-high-resolution imaging system

Final Note: Demura

If each display pixel can be measured, it's possible to remove non-uniformity caused by pixel-to-pixel variation by creating correction factors for each pixel.

For each R, G, and B pixel, corrections can be made using this method:

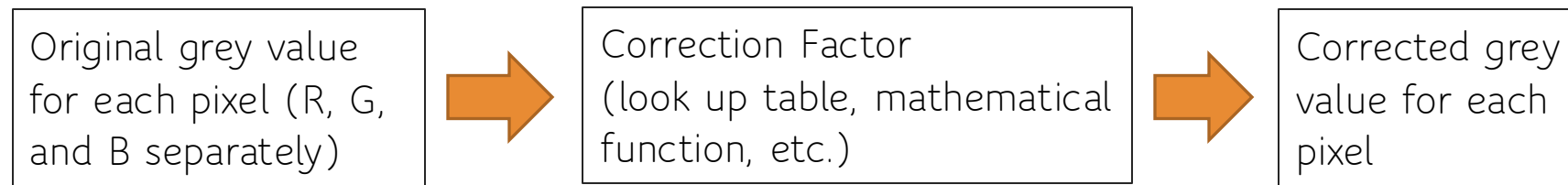

The process for creating the correction factors is called "demura" because it removes mura from the display (is used to "de-mura" the display).

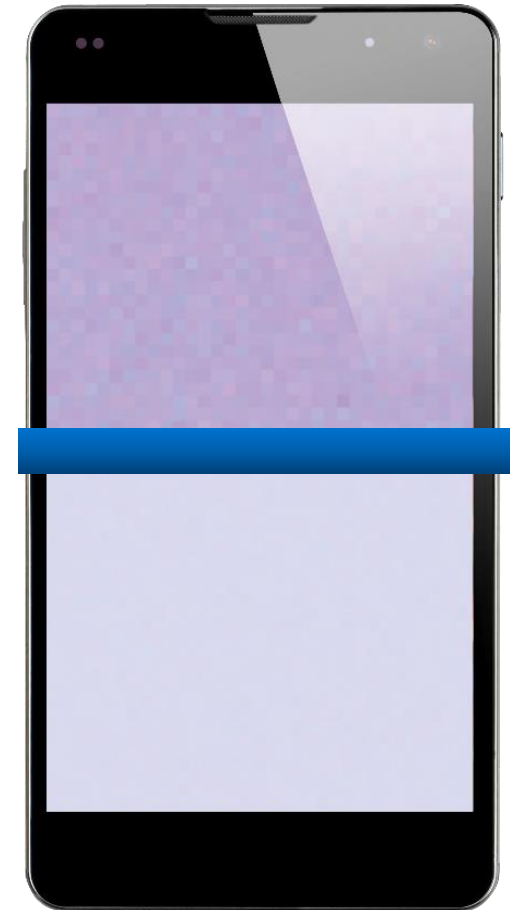
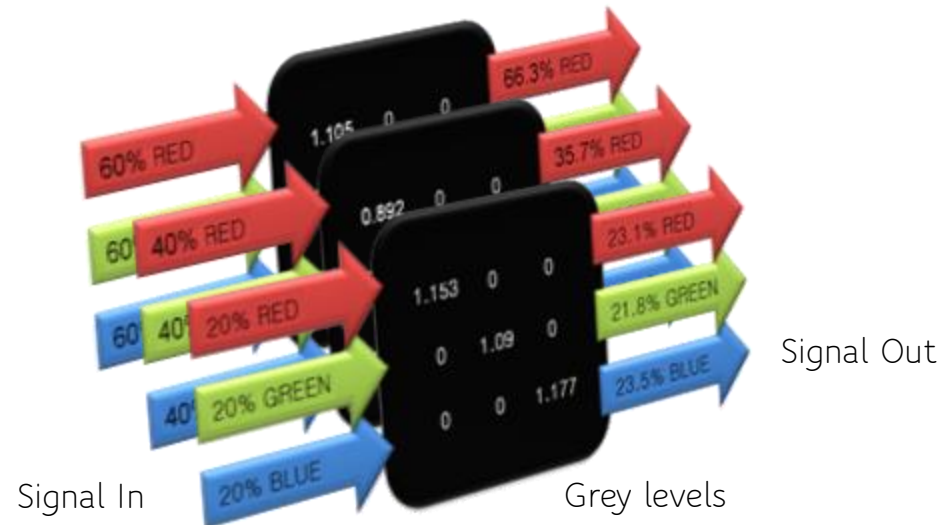

Before/after demura of an OLED smartphone display.

Directional View

Geometry of Observation

Even with the head of the observer fixed, each location on the display screen is seen from a different direction!

- This direction of observation is specified by two (e.g., polar) angles:
- angle of inclination (with resp. to display surface normal) θ
- azimuth (rotation) angle in the DUT plane ϕ
- ➔ the "viewing angle" is undefined lab-jargon ...

Particularly important for NEDs (user has $100^\circ+$ FOV)

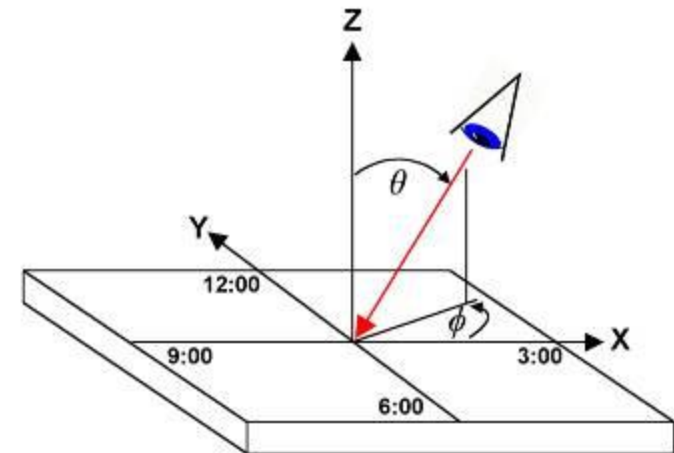
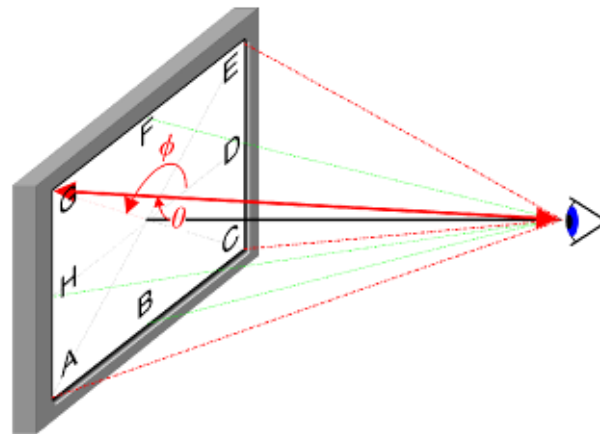
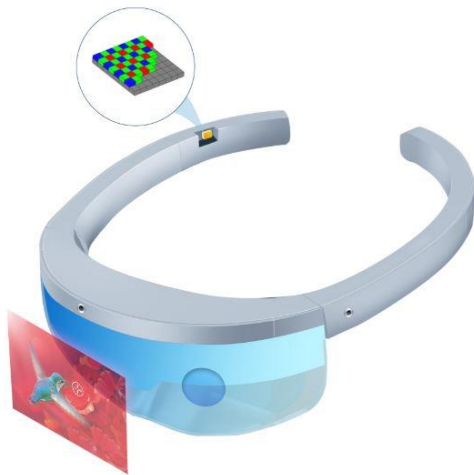

Impact of Viewing Direction

Impact on display performance

- Variation in luminance
- Variation in contrast
- Variation in chromaticity

Impact for the observer

- Loss or reduction of perceptibility of displayed visual information

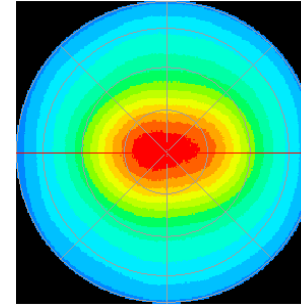

Luminance WHITE

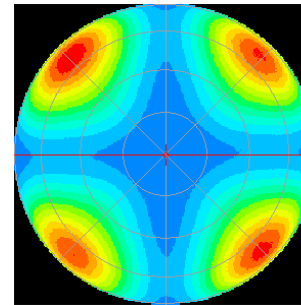

Luminance BLACK

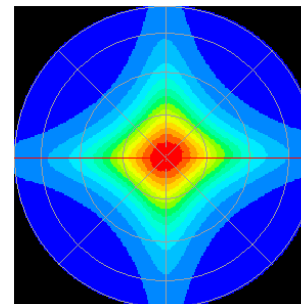

Contrast

Analysis of Variations with Viewing Direction

Gonioscopic approach:

- Motorized scanning of viewing cone (various kinematics)
- Various LMDs (photometric, spectrometric, imaging),
- Extremely high mechanical precision needed; i.e., for AR/VR products
- Slow, high precision, good control of all parameters.

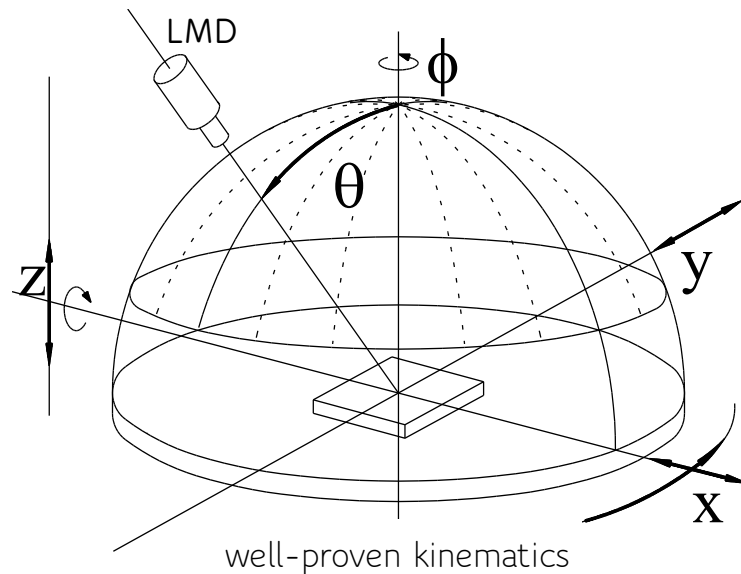

Example display measurement system

Conoscope Lens

Uses Fourier optics to transform a directional distribution of light rays emanating from a single point to a lateral distribution.

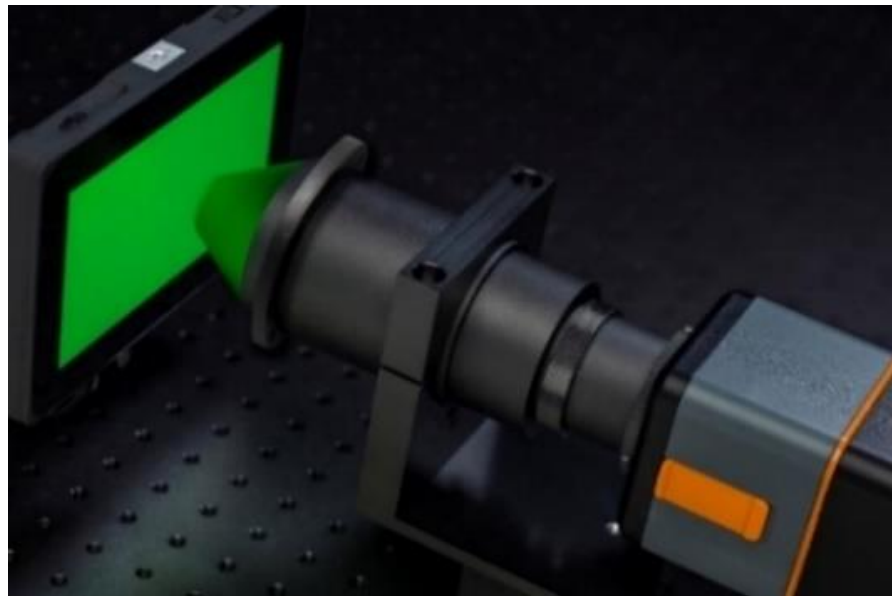

Example imaging system with conoscope lens

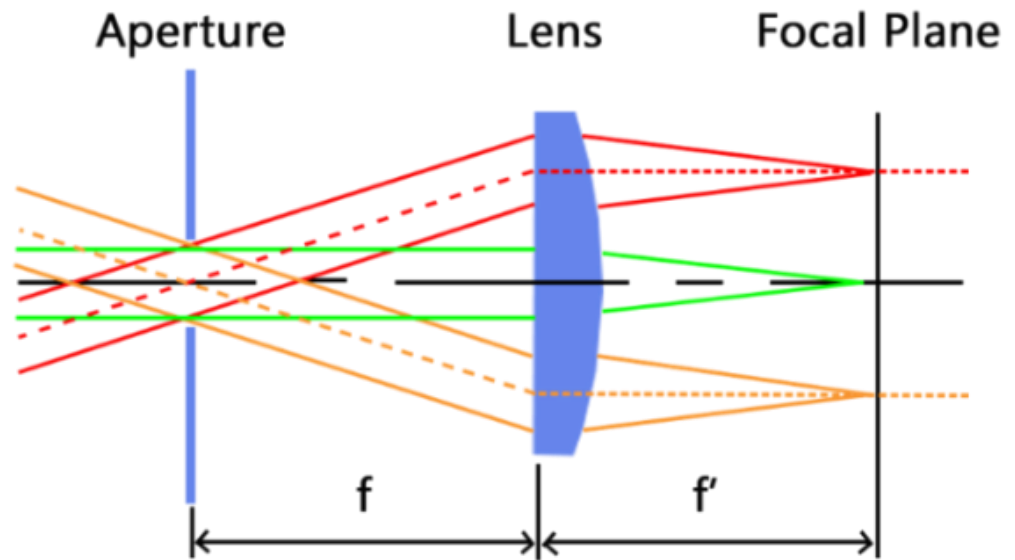

Conoscope Lens

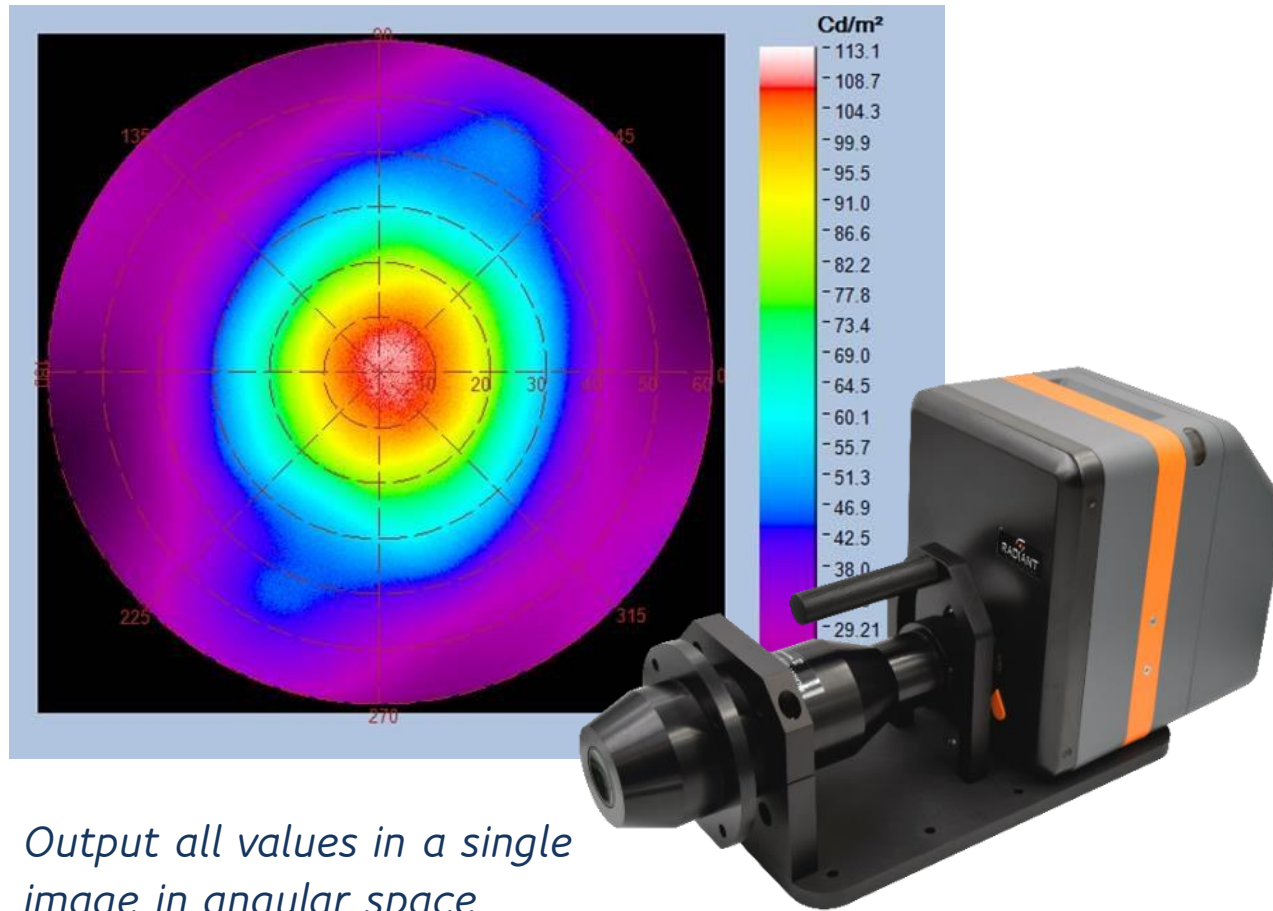

Output all values in a single image in angular space

Example imaging system with conoscope lens

Enables photometric imagers to capture a full cone of light emitted in angular space from a small sample on a display.

Significantly shorter test time for 9-point measurement at once.

Viewing Direction – Luminance

LC - DISPLAY

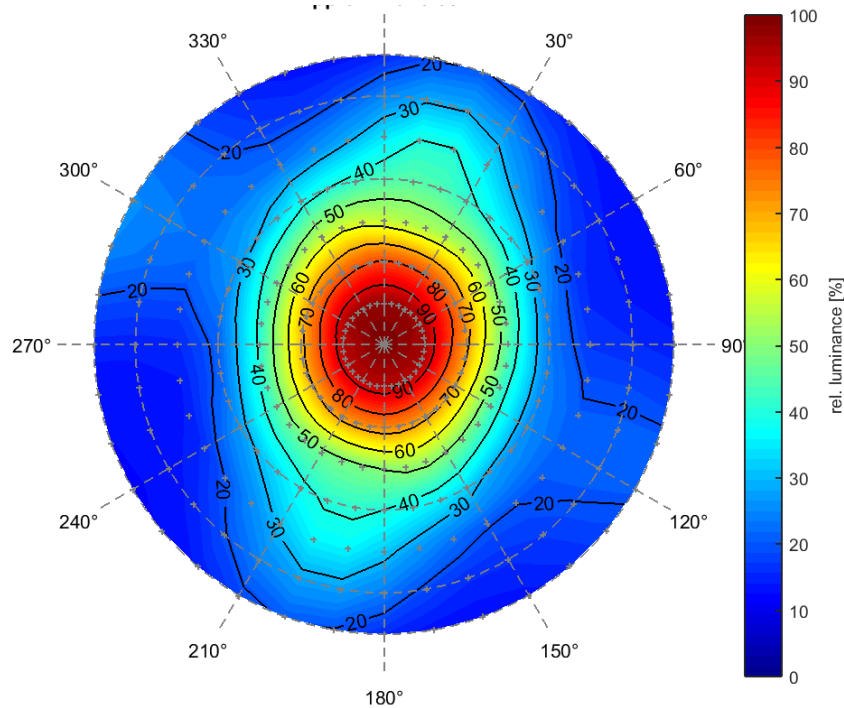

OLED - DISPLAY

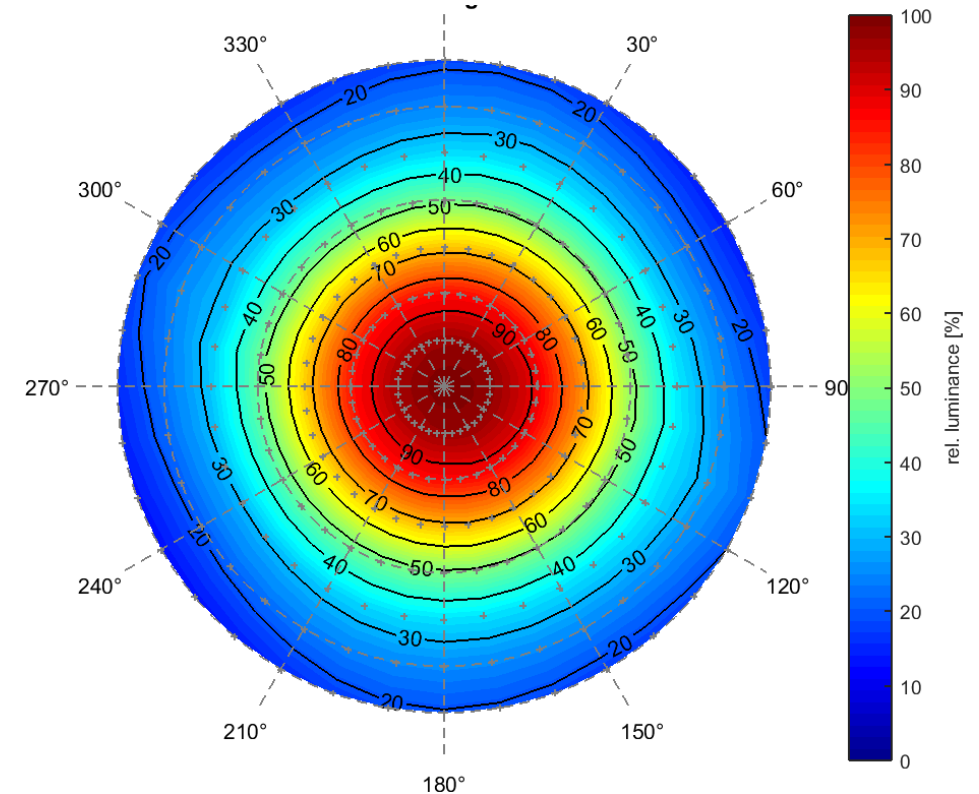

LCD are rotational non-uniform, OLED typically are uniform.

Luminance loss with increasing angle.

Viewing Direction – Chromaticity

LC - DISPLAY

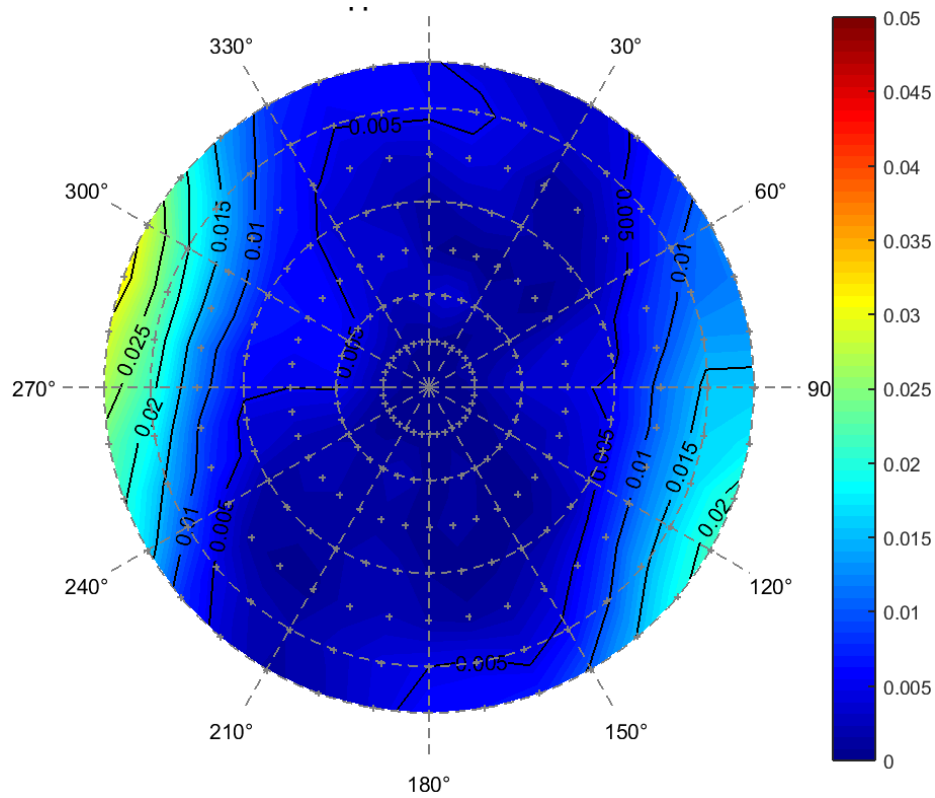

OLED - DISPLAY

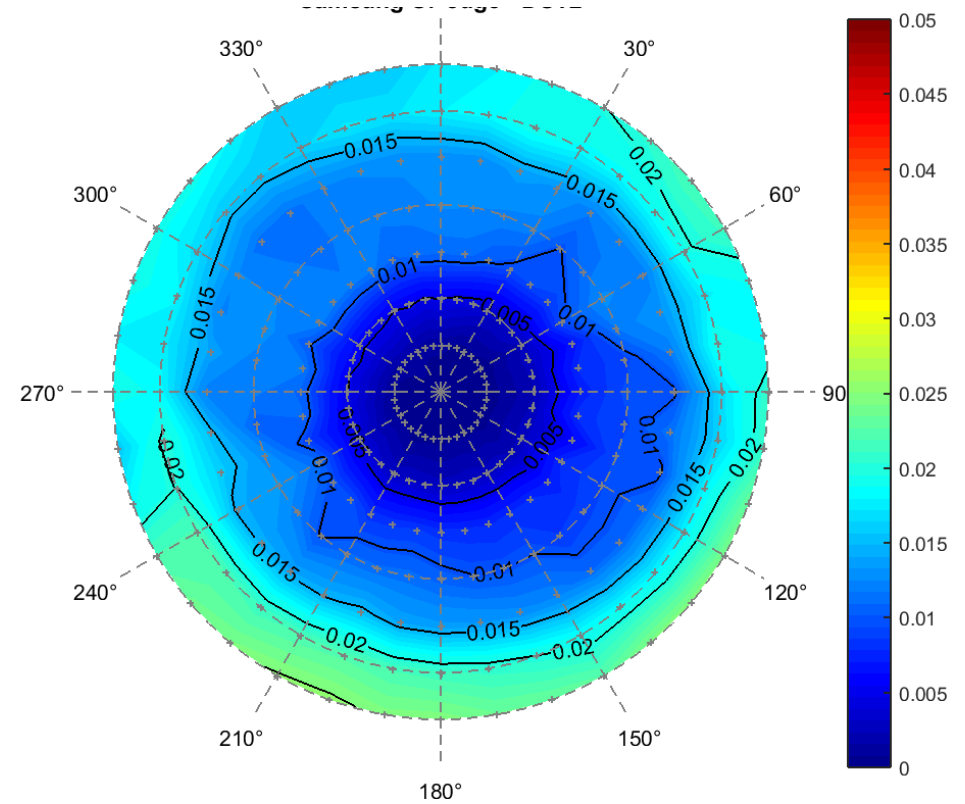

Chromaticity change typically more pronounced with OLED.

am-OLED Display Screen

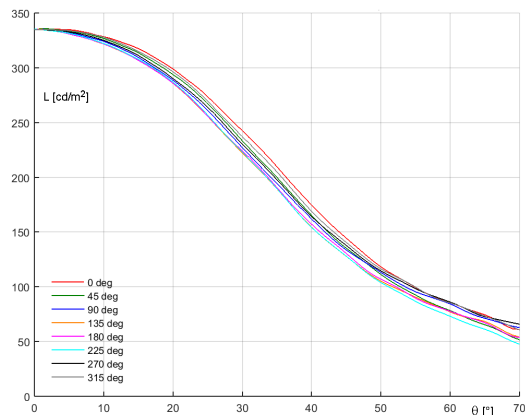
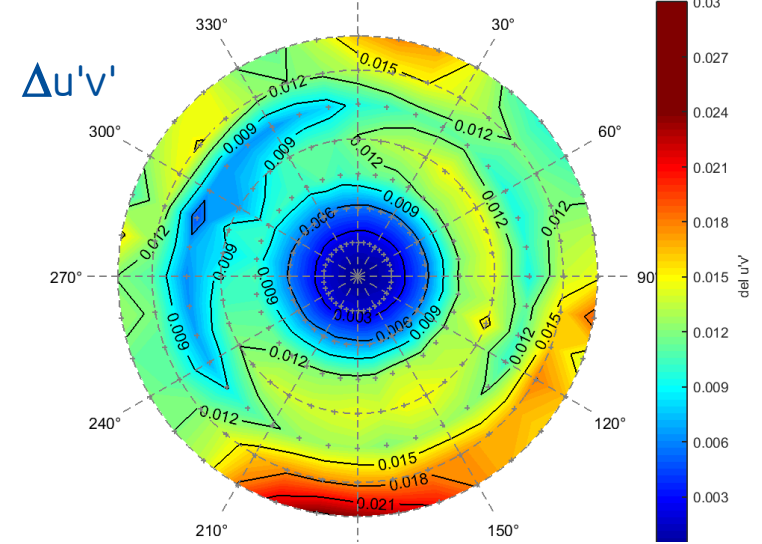
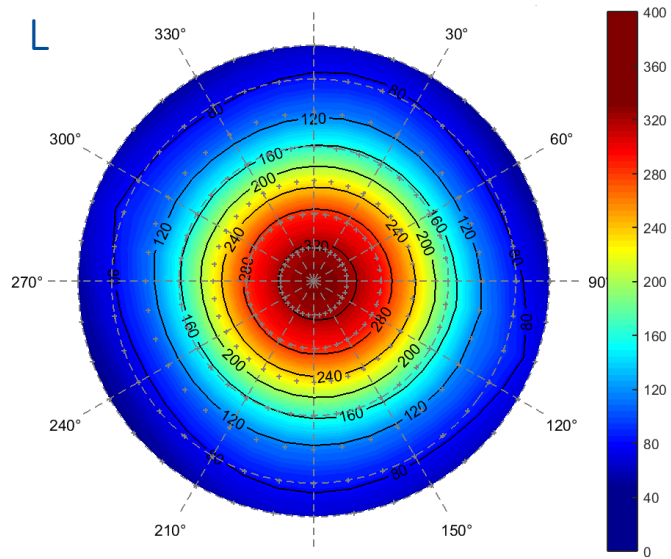

white test-pattern (255)
measurements & evaluations

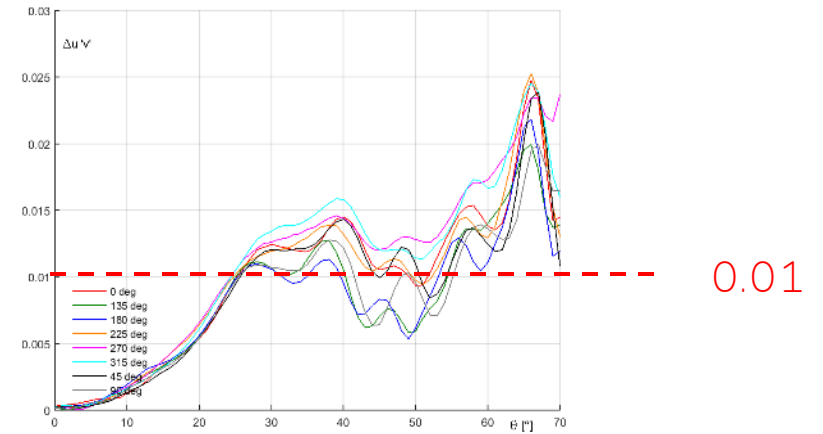

Accuracy: Conoscope on LCD

Equivalent measurement data as compared with 2-axis goniometer

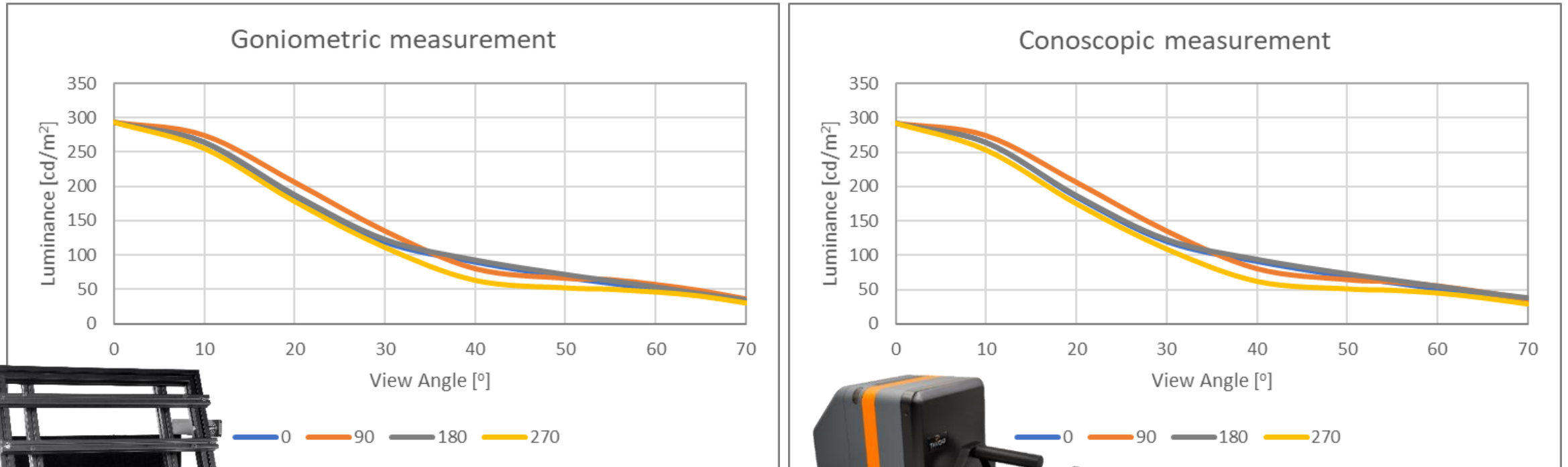

Example 2-axis goniometer

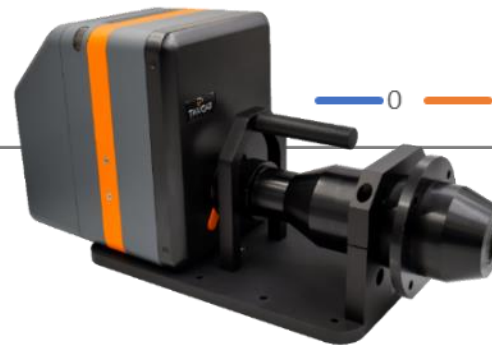

Example imaging system with conoscope lens

IV. Addressing Emerging Display Types & Integrations

ADAPTING MEASUREMENT METHODS TO ENSURE QUALITY FOR
THE LATEST DISPLAY DEVICES

MiniLED, MicroLED & MicroOLED

Challenges: Small Size & Pitch



Entire Display - All Pixels - One Shot

0.5" Monochrome μ LED Display
~ 8 μ m pixel size
~ 10 μ m pixel pitch

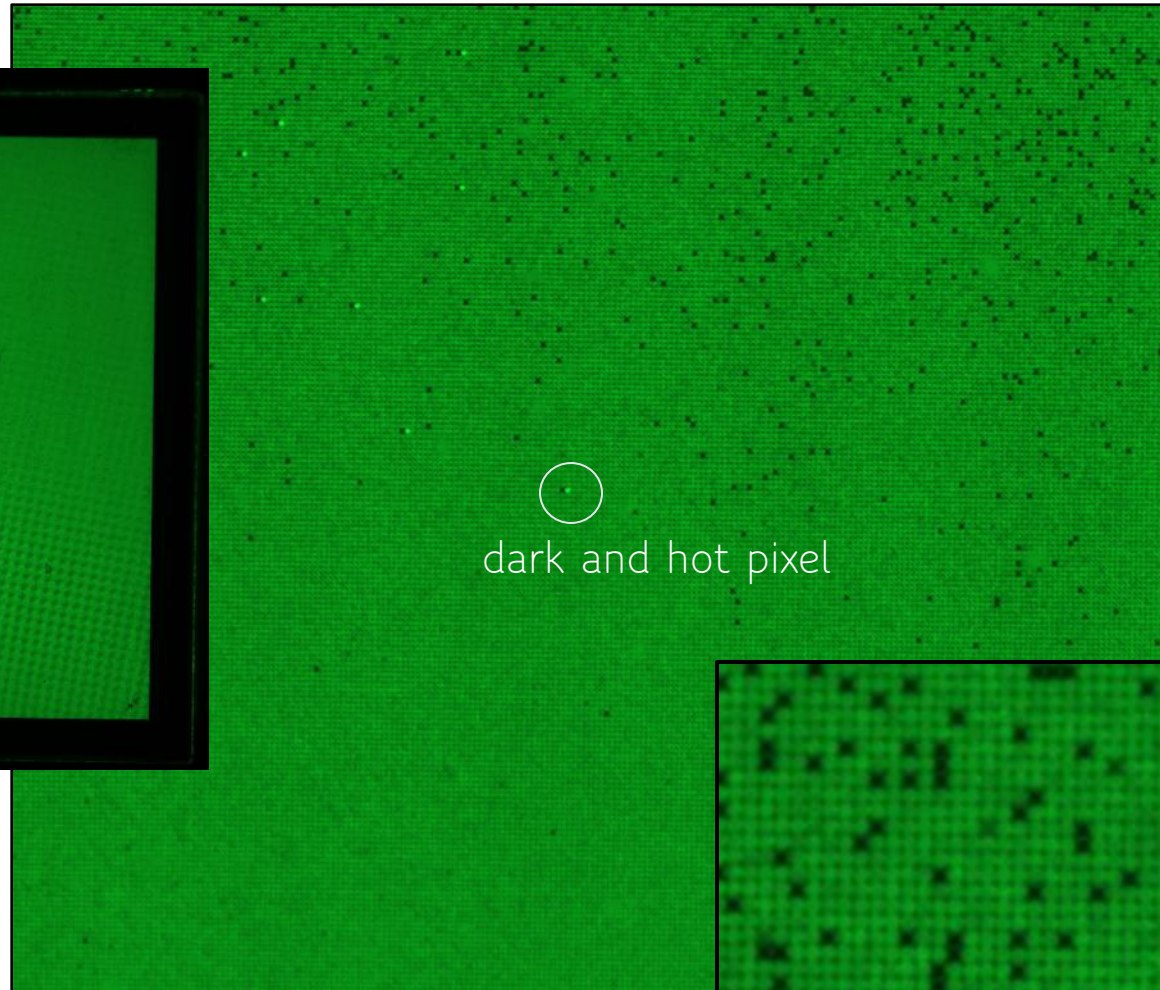

Challenges: High Number of LEDs / OLEDs

E.g. on assembled display

- Requires high pixel number

E.g. on wafer

- Requires high-speed measurement

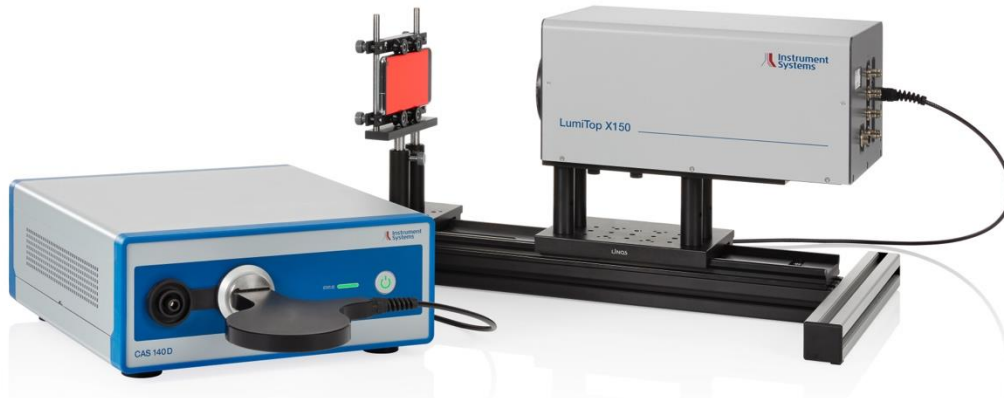

Example high-resolution, spectrally enhanced imaging colorimeter

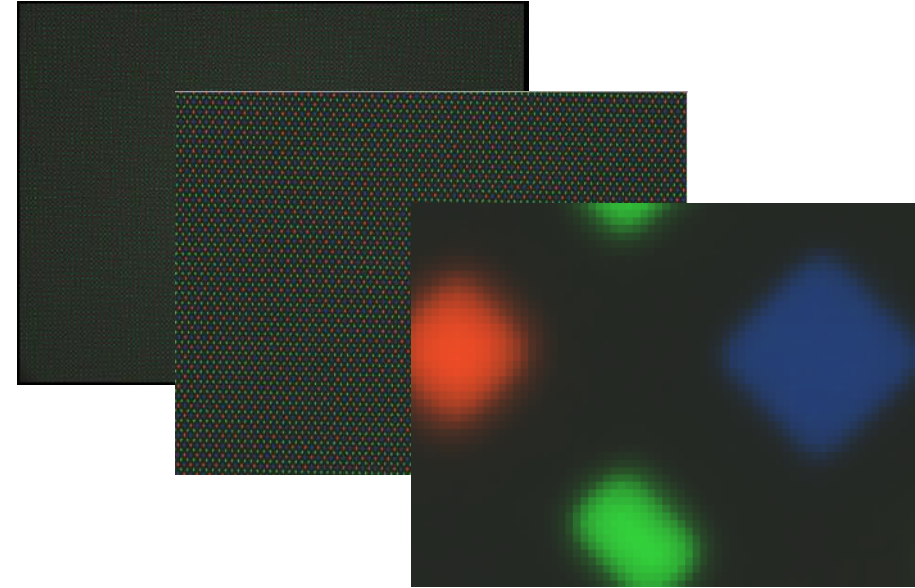

"Pixel 3" measured with 600MP full-color sampling

Challenge: Non-linearity of μ LEDs

White

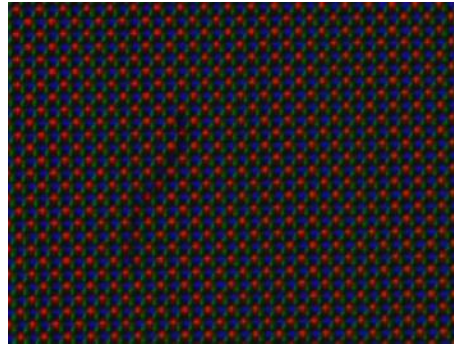

Grey level 5

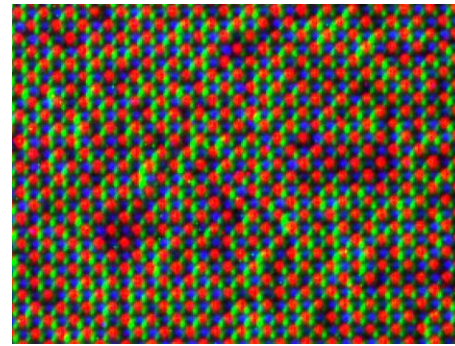

Red



Green



Blue

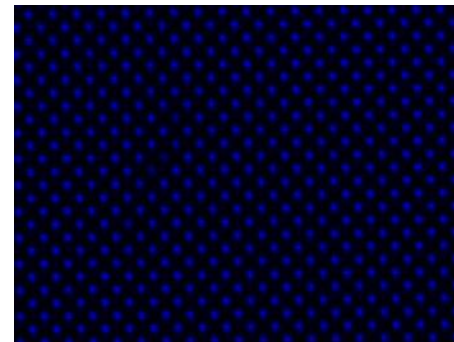

Example high-resolution images for different color patterns including dark grey

Example Measurement: 1" OLED μ Display

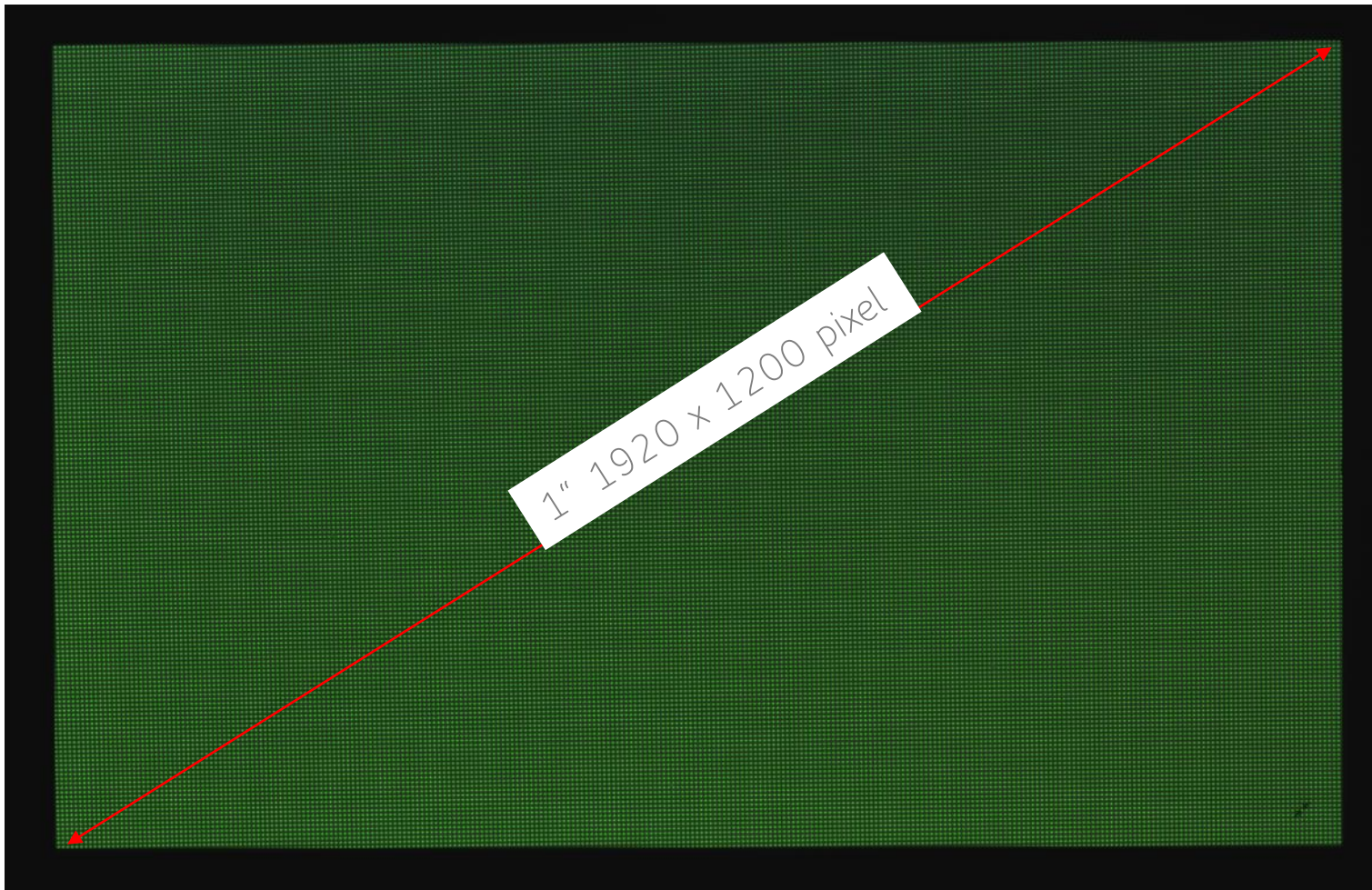

Group of Dr. Vogel and
P. Wartenberg, Fraunhofer FEP
 μ OLED Display
2300ppi
2x magnification lens

Example Measurement: 1" OLED μ -Display

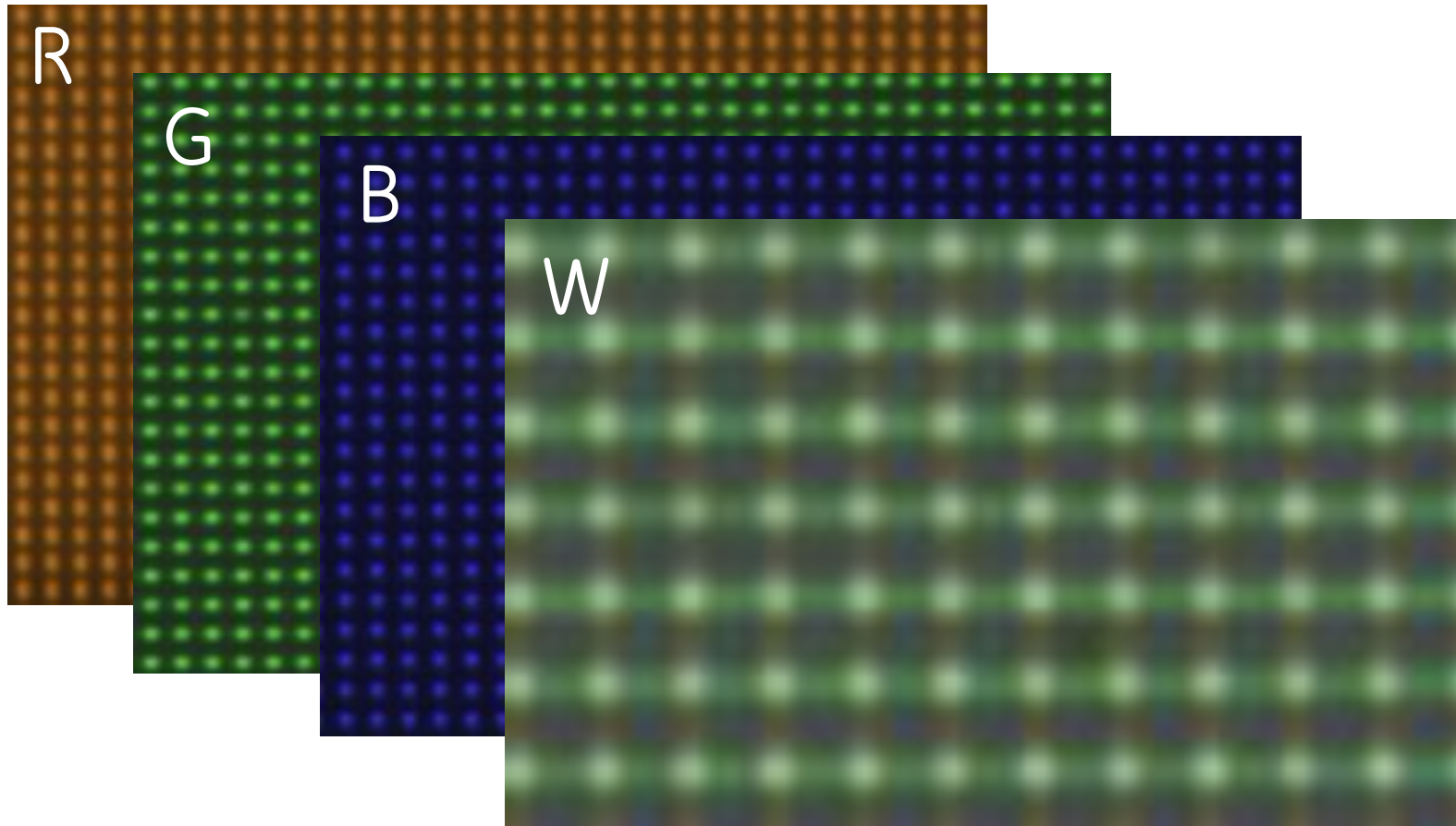

RGBW pixel setup
 μ OLED Display
4600 subpixel ppi
5.5 μ m subpixel pitch

Wartenberg, P., Buljan, M., Richter, B., Haas, G., Brenner, S., Thieme, M., Vogel, U. and Benitez, P. (2018), 40-5: *Invited Paper: High Frame-Rate 1" WUXGA OLED Microdisplay and Advanced Free-Form Optics for Ultra-Compact VR Headsets*. SID Symposium Digest of Technical Papers, 49: 514-517. <https://doi.org/10.1002/sdtp.12447>

Solutions: Pixel-Level Measurement

Imaging photometers & colorimeters can capture millions of pixels at once to quickly measure:

- Luminance
- Chromaticity
- Non-uniformity
- Stuck-on/off pixels
- Correction factors (demura)

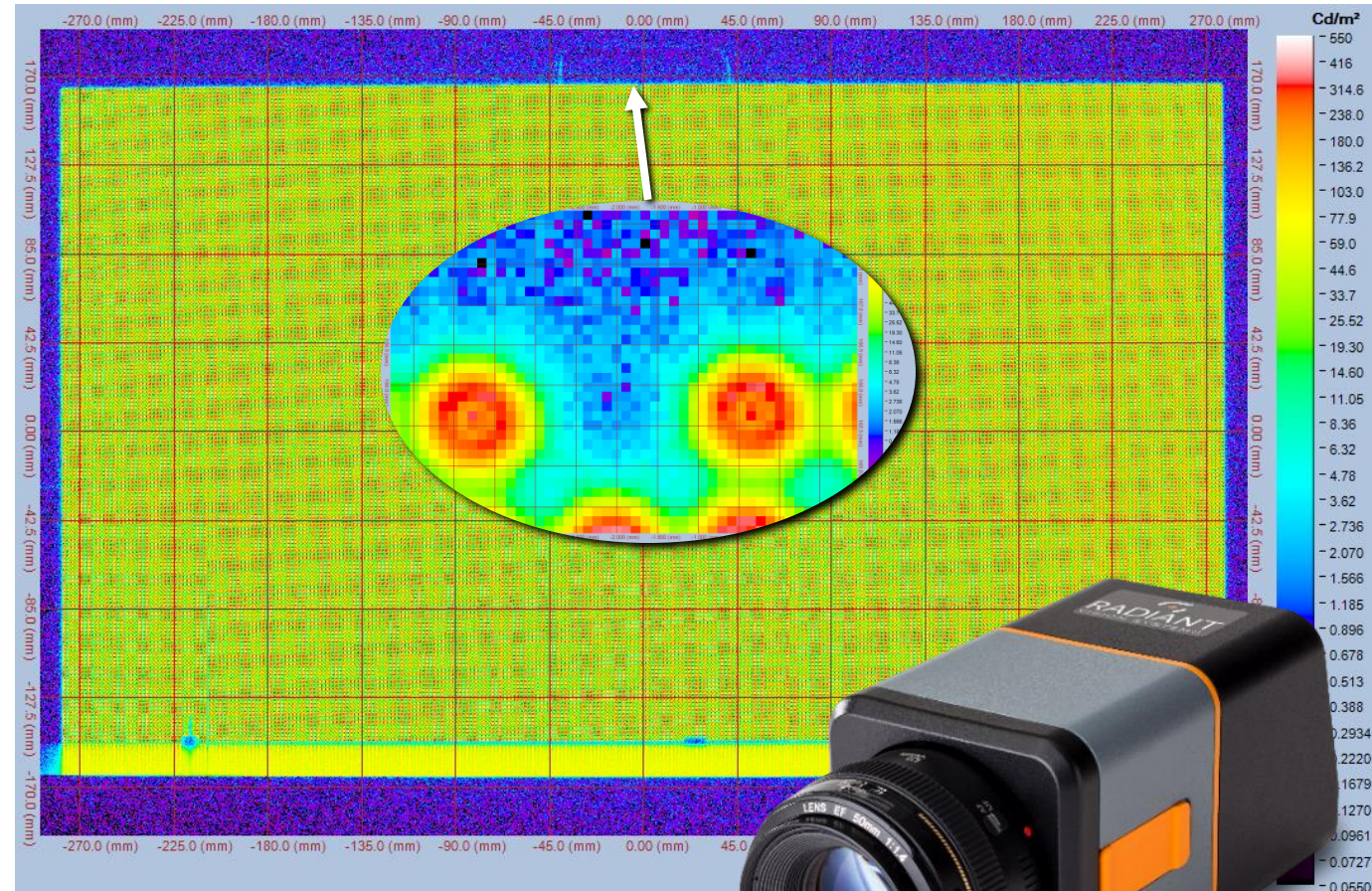

Example imaging photometer



Solutions: Microscope Lens

Used for:

- Individual LED or subpixel measurement
- Measuring at the chip or wafer level
- Off-line testing
- Testing in sections

Measure luminance & chromaticity of subpixel

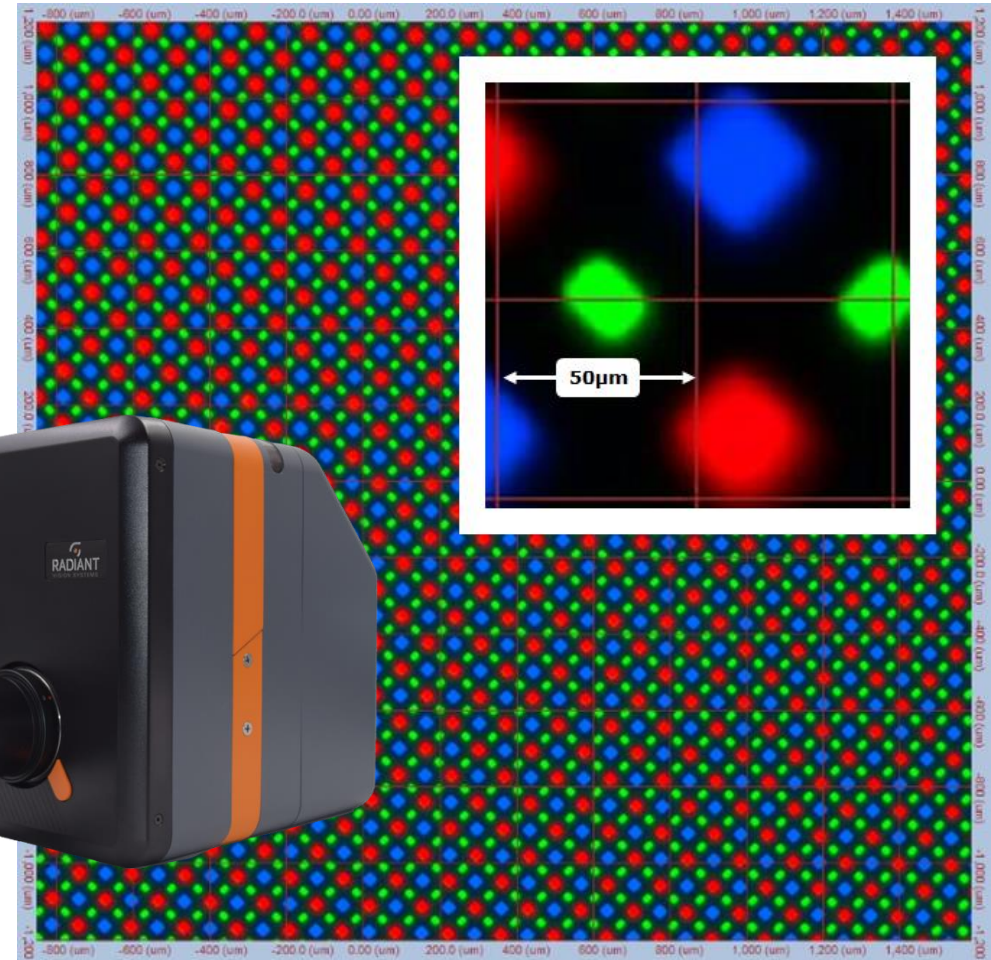

Example imaging photometer with microscope lens

Solutions: Testing μ LED Wafer

Traditionally, contacting of individual LEDs. Electroluminescence measured via an integrating sphere.

- Proven method of LED testing

2D measurement of photo- or electro-luminescence of a wafer with LumiTop leads to comparable results but is much **faster**.

- Proven **one-shot** method of display testing

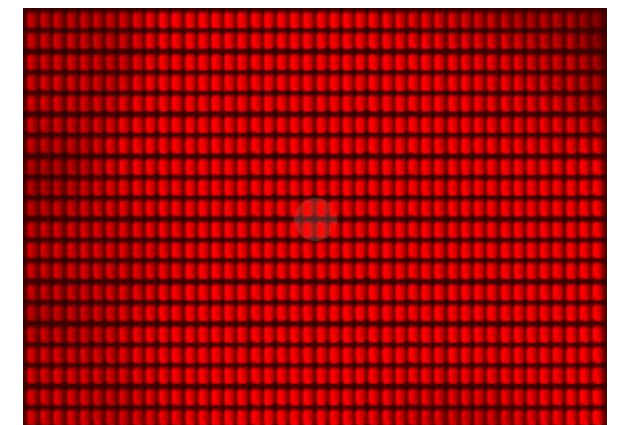
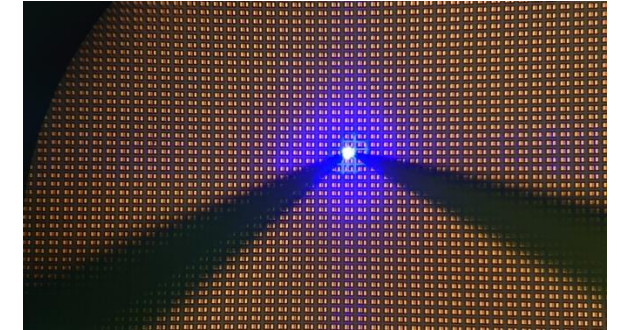
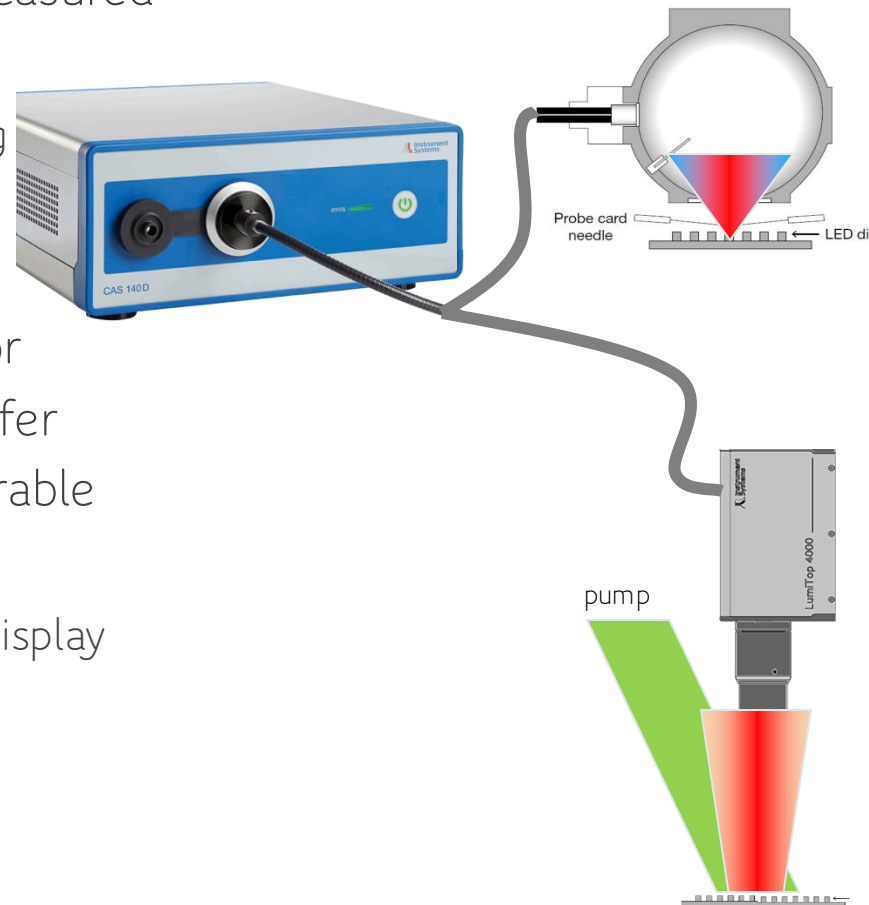

Solutions: Testing μ -LED Wafer or Small Displays

Typical DUT properties

- Emitter Size / Pitch: 30 μ m - 200 μ m
- Desired field of view: few mm - few cm
→ Number of emitters: few 100 - few 100k
- Energizing
 - μ LED: Probe card & current source
 - μ LED PL: UV light source
 - Small display: Driver by software interface
 - Projection modules: Probe card / driver



Example high-resolution, spectrally enhanced imaging colorimeter

Light Measurement Devices & Software

- Image-based system
- Fast, with advanced trigger scheme
- Microscopic lens or macro objective
- Algorithms for individual emitter evaluation

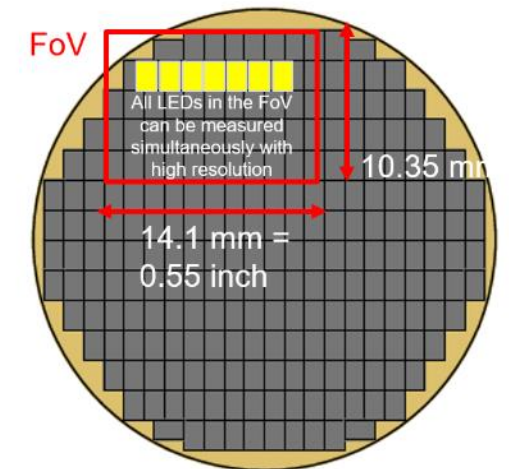

Solutions: Full Display Characterization

Typical DUT properties:

- Emitter Size / Pitch: 1 μm - 200 μm
- Desired field of view: few mm - few m
→ Number of emitters: 1 M - few 10 M

Light Measurement Devices & Software -
Additional requirements:

- Extremely high-resolution, image-based system
- Variety of lenses
- Efficiency of algorithms

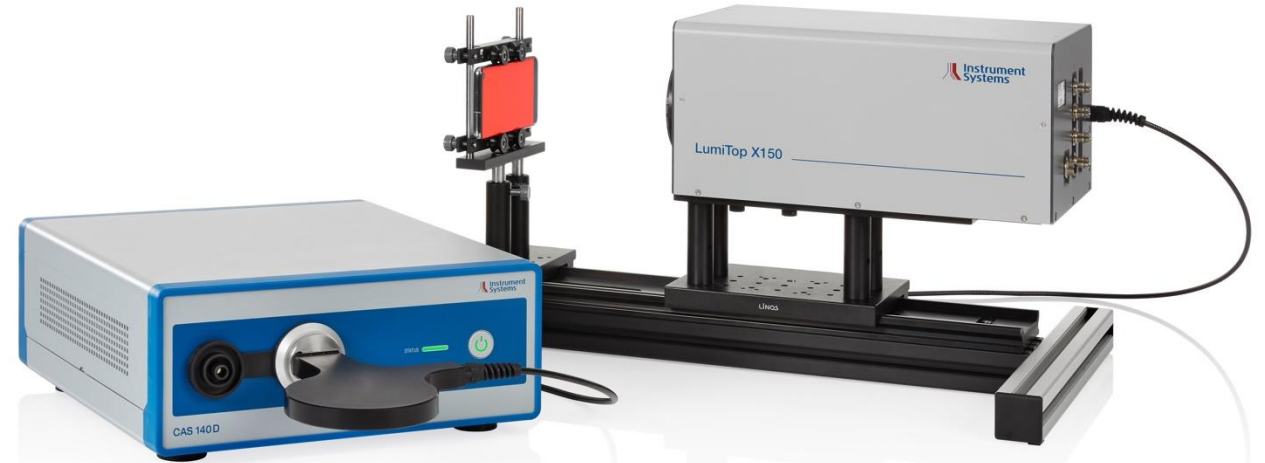

Example ultra-high-resolution imager

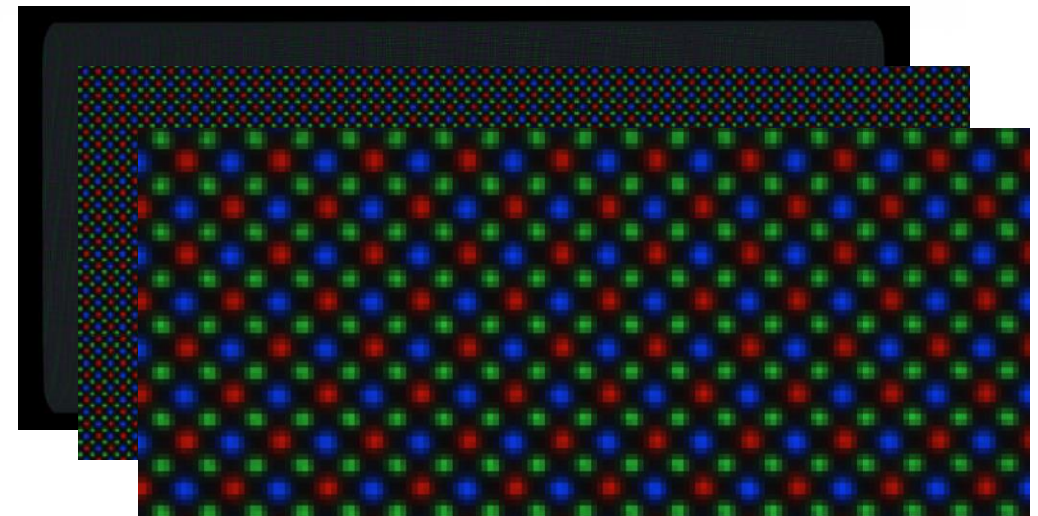

Solution: Live Color Calibration

- μ LEDs show narrow spectra and spectral variation.
- Imaging light measurement devices often have a static color calibration.
 - Spectral difference (between calibration and measurement) introduces a color error
- For accurate measurements the imaging light measurement system should include a traceable reference spectrometer.
 - For optimal color values calibration should be calculated live on the DUT.

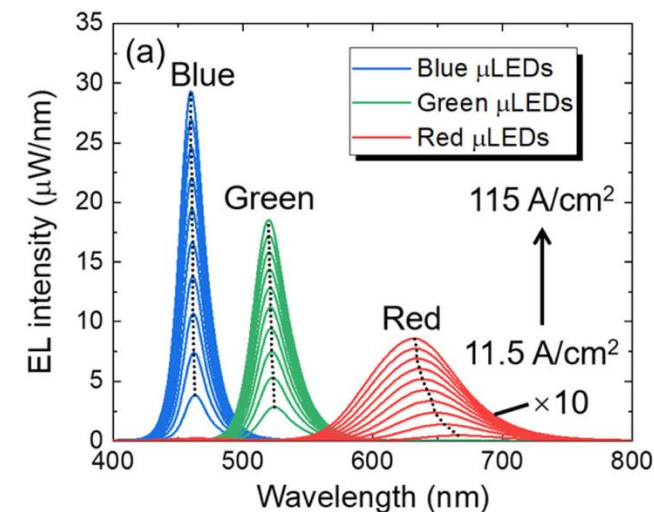
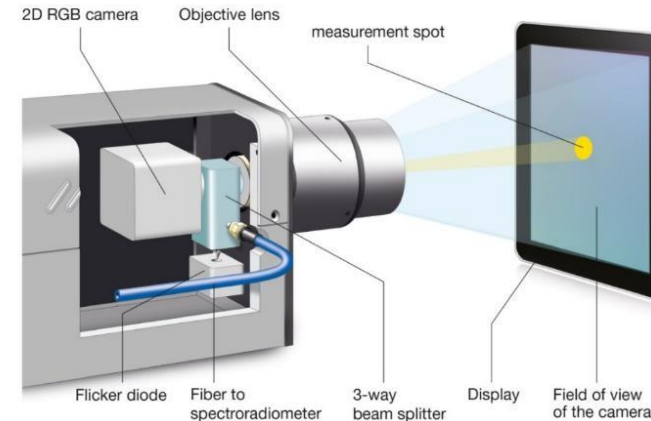

Augmented & Virtual Reality

The Landscape of XR

Headset	Type	Display	FOV (H)	Resolution (per eye)
HTC VIVE Pro 2	VR	LCD	120°	2448 x 2448
Oculus Quest 3	VR	LCD	110°	2064 x 2208
HP Reverb G2	VR	LCD	114°	2160 x 2160
Varjo VR-2	VR	AMOLED	87°	1920 x 1080
HoloLens 2	AR	Waveguide	43°	2048 x 1080
Vuzix Blade	AR	Waveguide	19°	480 x 853
Magic Leap 2	AR	Waveguide	70°	1440 x 1760



Unique Viewing Conditions

Within a headset, a user views a display:



Extremely close to the eye
(near-eye displays, or NED)



Across wide fields of view
and often dual-eye



Within limitations of the
headset architecture

Replicating the Human Visual Experience

An AR/VR test system must replicate the visual experience:

- Ensure aperture captures equivalent detail as the human eye (roughly 2-8 mm pupil size)
- Ensure aperture is positioned at the same place as the human pupil to visualize the display through the headset
- Ensure aperture position and lens field of view capture display FOV and reflect the human visual FOV (roughly 114-120° for binocular vision)

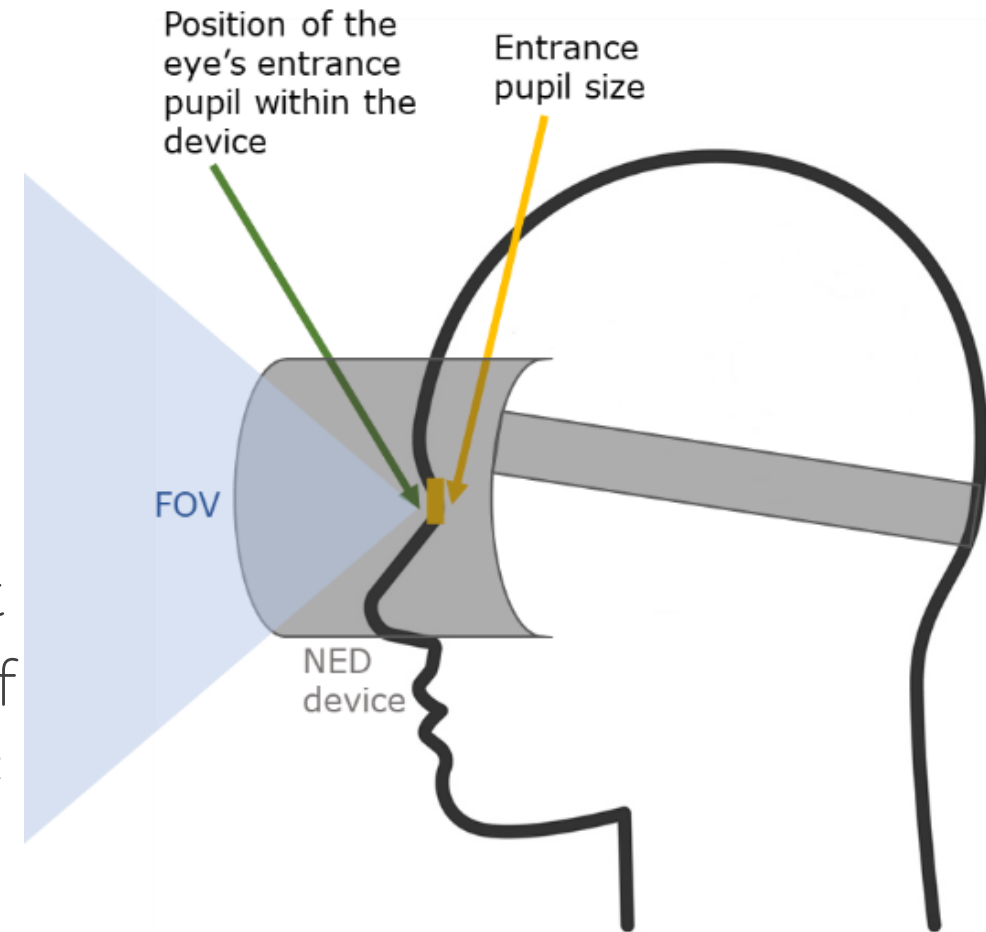

Entrance Pupil Position

Standard Lens

Aperture inside lens; occlusion from AR/VR device hardware

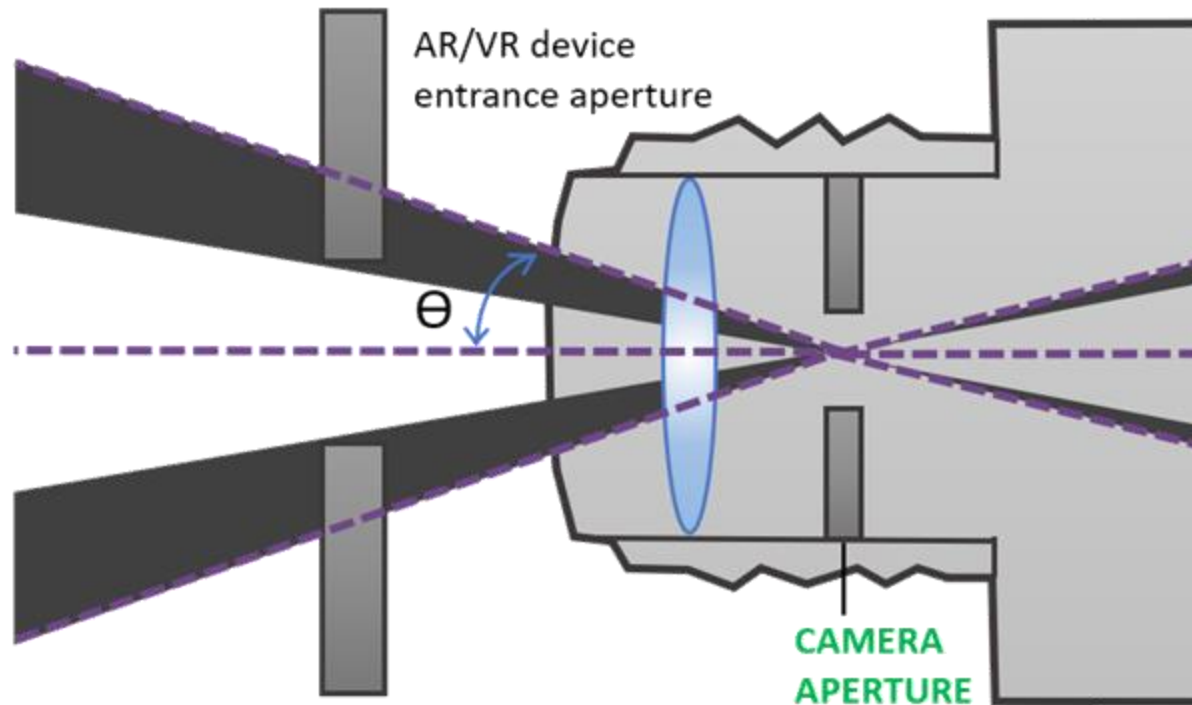

*Entrance pupil far from opening;
field of view is occluded.*

Entrance Pupil Position

AR/VR Lens

Aperture at front of lens; no occlusion

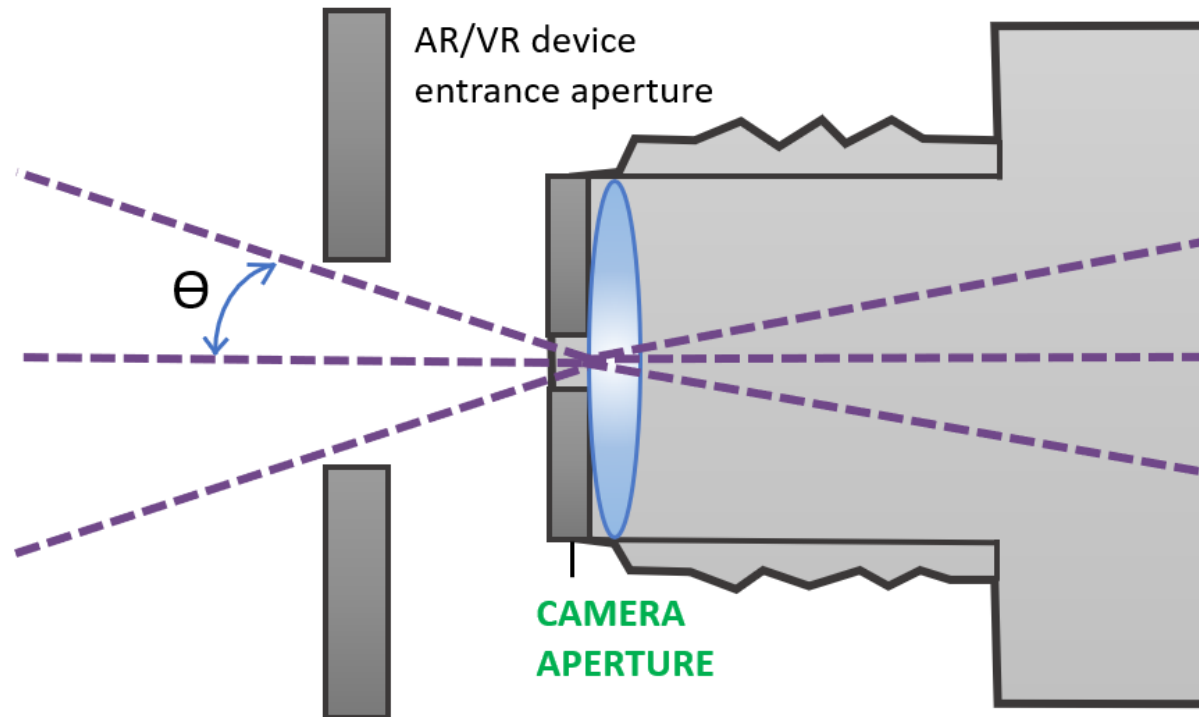

Entrance pupil far from opening.



Entrance pupil at opening; full FOV.

Example AR/VR Test Systems



Example AR/VR lens with entrance pupil at front of lens; straight design

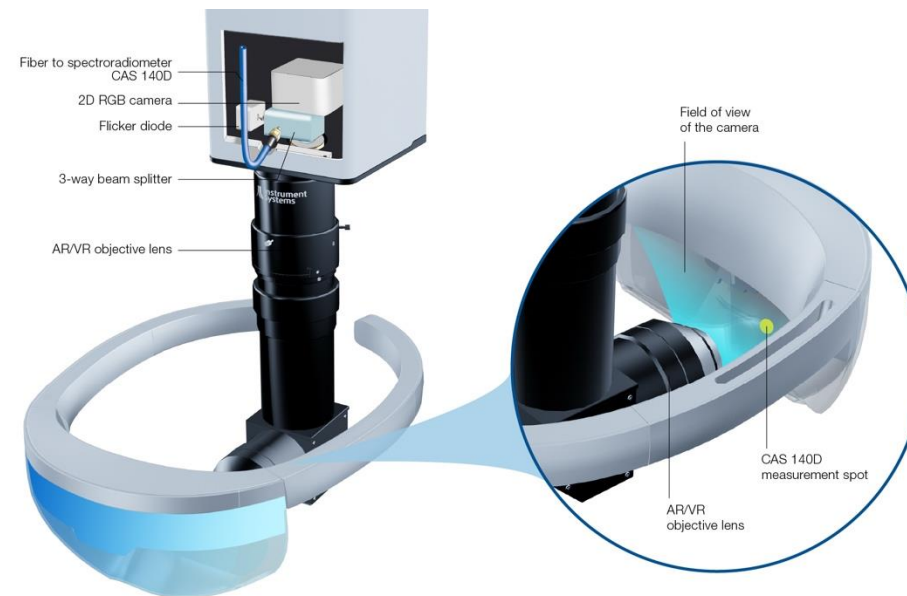

Example AR/VR lens with entrance pupil at front of lens; periscope design



Example of optical Probe for AR/VR Spot Measurements (can be combined with a goniometer)

System Calibration

AR/VR display test systems must be calibrated to overcome challenges:

1. Accuracy of luminance and color measurement
 - Flat field calibrate to get uniform luminance and color response across a wide angular FOV
2. Distortion in measurement system
 - Most wide-FOV (fisheye) lenses exhibit distortion
 - Calibrate via image processing to accurately test XR display in using 2D image analysis functions

Goniometer:

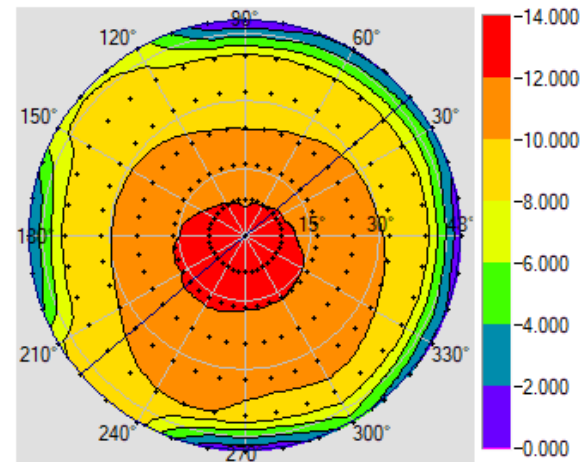

LUMINANCE ACCURACY

Imager with WFOV Optics:

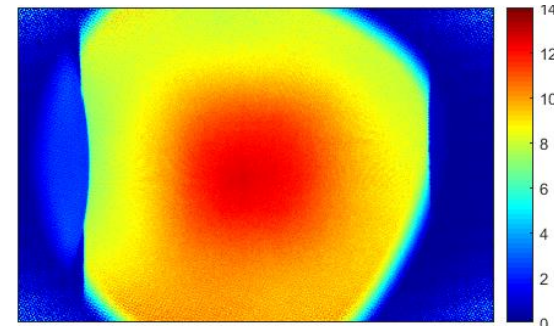

Before calibration

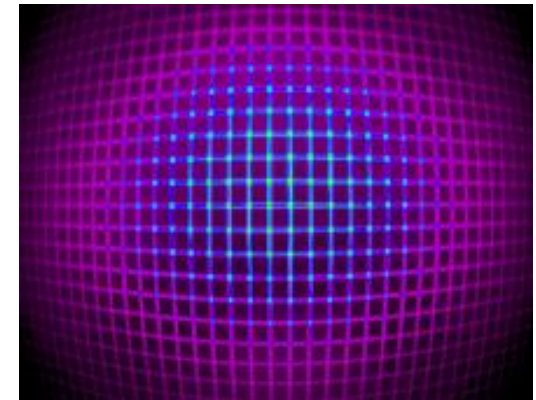

After calibration

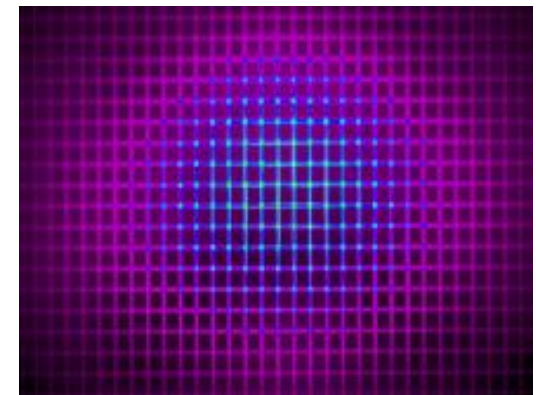

DISTORTION ACCURACY

AR/VR Display Analyses

Once a measurement image of the full display field of view has been captured and calibrated, several analyses can be run:

- Luminance
- Chromaticity
- Contrast
- Distortion
- Field of View Measurement
- Focus Uniformity
- Line Defect Detection
- Mura
- MTF (Modulation Transfer Function)
 - Slant Edge
 - Line Pairs
 - Line Spread Function (LSF)
- Pixel/Dot Defect Detection
- Point-of-Interest Evaluation
- Uniformity
- Warping

Example Analysis: Field of View

A Field of View analysis measures the actual field of view of the display as imaged within the headset, ensuring that the horizontal, vertical, and diagonal dimensions are correct to design specifications. These measurements can also be reported on a specification sheet for the XR headset.

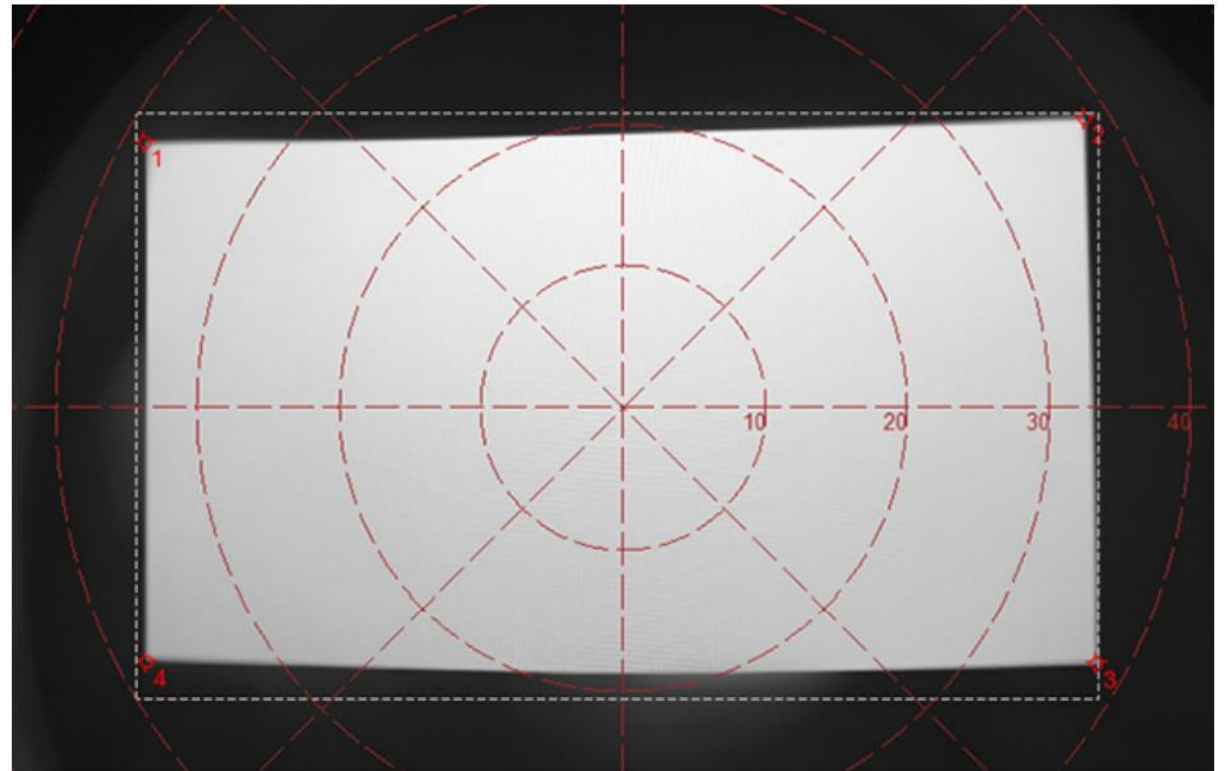

Result	Value	Unit
Horizontal FOV	66.504	Degrees
Vertical FOV	37.488	Degrees
Diagnol FOV	76.342	Degrees

Example Analysis: Uniformity

Uniformity analysis determines areas of low or high luminance across the display, which may indicate a defect in the display. This analysis can also be used to characterize the uniformity against design specifications.

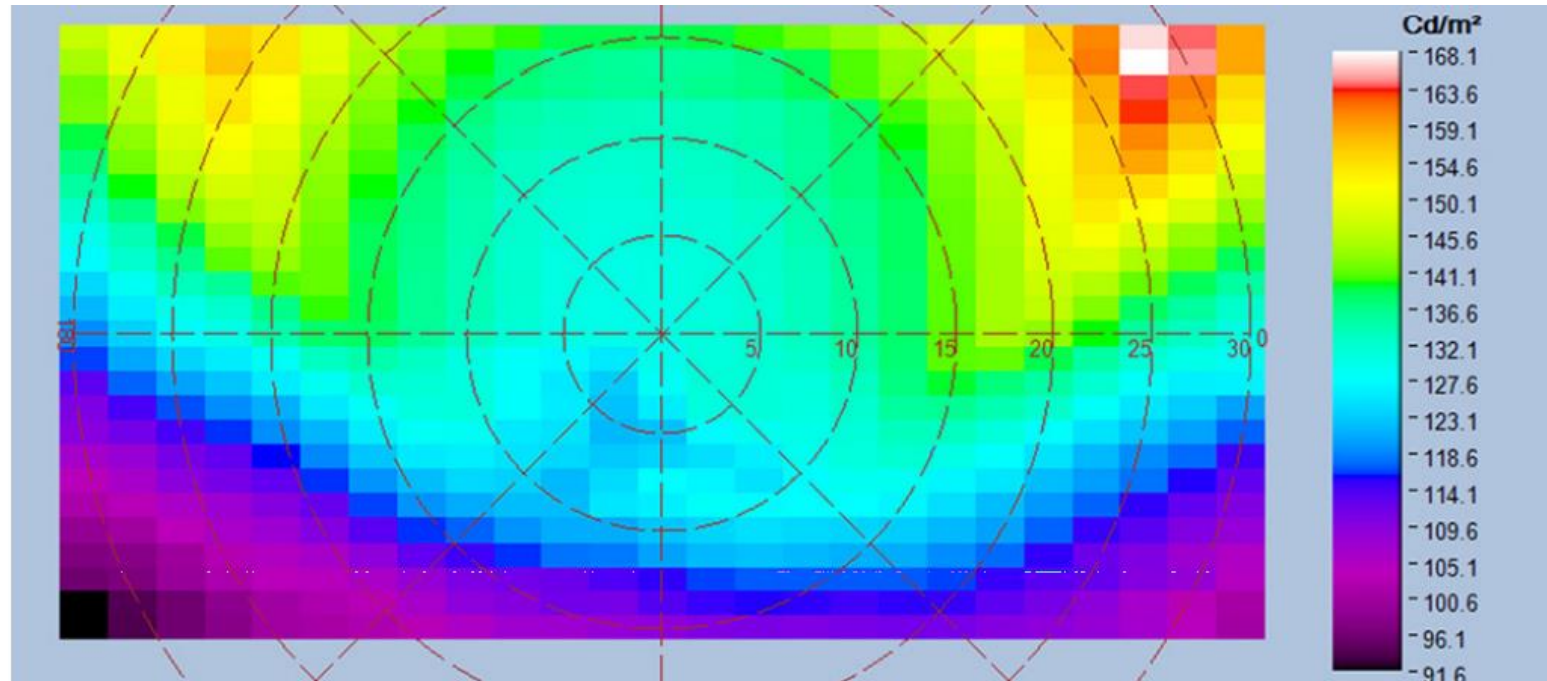

Example Analysis: MTF (Slant Edge vs. LSF)

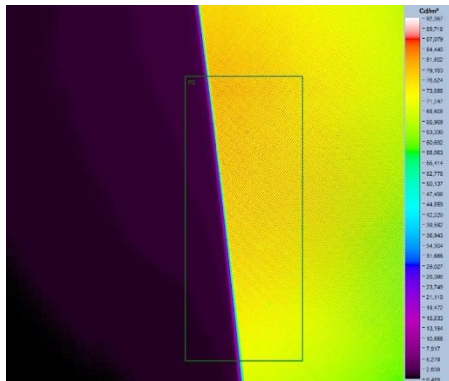

Slant Edge Method

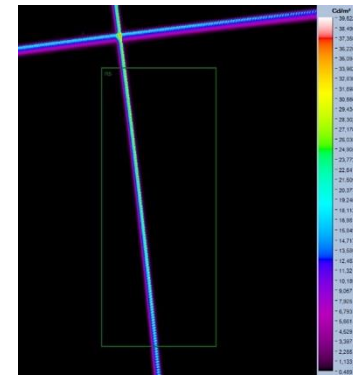
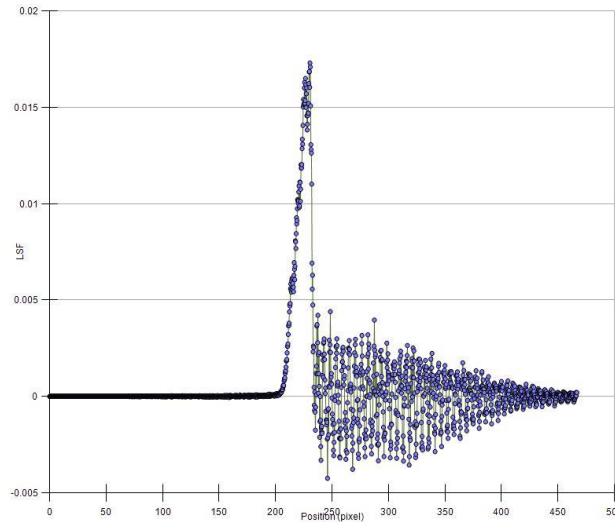

Line Spread Method

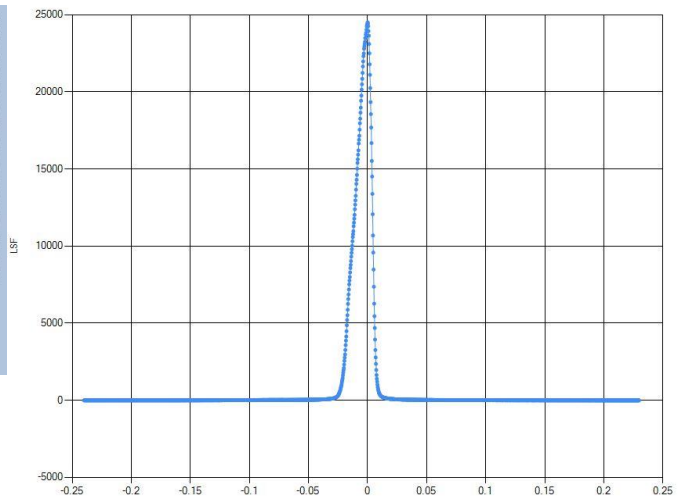

False MTF peak

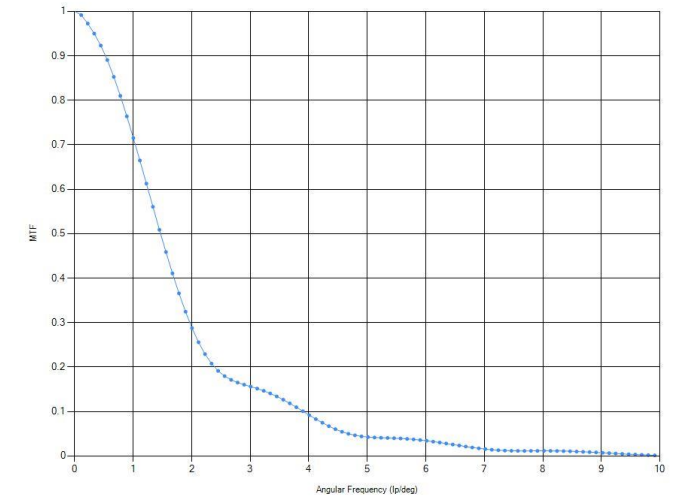
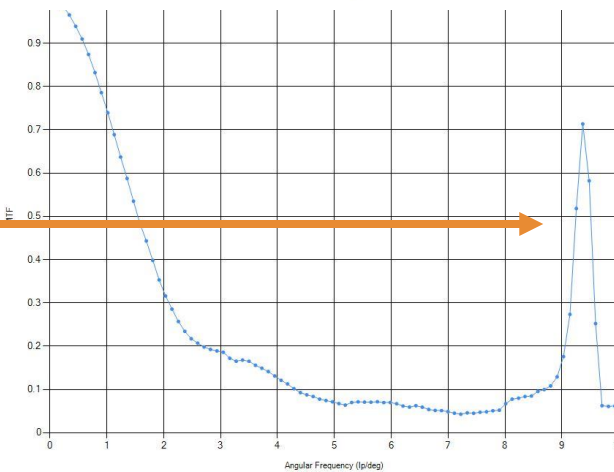

Summary

Radiant Vision Systems and Instrument Systems products meet a range of measurement and inspection applications:

- Ensures the intended performance of a display device
- Pinpoints and quantifies quality issues and defects
- Allows pass/fail determinations to be automated against a consistent standard, from device to device, line to line, and supplier to supplier
- Enables manufacturers to increase yield





Thank you.

Connect with us and learn more about display metrology on our websites.

▶ Matt Scholz | [RadiantVisionSystems.com](https://www.RadiantVisionSystems.com)



A Konica Minolta Company